

MODEL IAMS – INTELLIGENT UNIVERSAL SIGNAL CONDITIONING MODULE



- UNIVERSAL INPUT, PROCESS, mA DC, VDC, TC, 100 (RTD, POTENTIOMETER, AND LINEAR RESISTANCE)
- UNIVERSAL POWER SUPPLY, 21.6 to 253 VAC/ 19.2 to 300 VDC
- 3-WAY ISOLATION (POWER/SIGNAL/OUTPUT)
- CHOOSE SETPOINTS AND/OR ANALOG OUTPUT MODELS
- PROGRAMMING/DISPLAY MODULE
- PROGRAMMING AVAILABLE IN SEVEN DIFFERENT LANGUAGES



GENERAL DESCRIPTION

The IAMS — Universal Signal Conditioners unmatched capability provides users the ultimate in flexibility. As a signal conditioner, the unit provides complete isolation and conversion capability to satisfy almost any application. The Universal Input accepts Process, DC Current, DC Voltage, Thermocouples, RTDs, Potentiometers, and Linear Resistance signals allowing the module to be connected to most common sensors. The setpoint model allows dual setpoint control capability through dual Form A relays. The analog model provides a retransmitted analog signal. A third model provides both analog and control capability. The power supply is also universal, accepting 21.6 to 253 VAC/ 19.2 to 300 VDC as its power source. Add the optional programming module and the unit is easily programmed through menu style programming. The module can also be used to provide a display of the process variable when it is not being used for programming.

The IAMS features well over 100 combinations of inputs to outputs configurations. Input specific terminals allow for the various signals and sensors to be connected to the unit while the input ranges and resolutions are adjusted in the input programming loop of the unit. The menu style programming allows the user quick and easy set-up by using the PGMMOD, programming module. The module is required to program the IAMS. However, if you are using more than

one IAMS, only one programming module is required. The module can store programming from one unit and load it to a second unit reducing set-up time for multiple installations. When the programming module is not being used for programming, it can indicate the input parameters, just like a panel meter.

The unit's overall full scale accuracy typically exceeds 0.1 % depending on the range selection and scaling. The microprocessor based design provides ease of field scaling and the onboard E²PROM stores scaling values for future recall. All units come factory precalibrated for all input and output ranges. Factory or custom field scaling can be selected in the Advanced programming loop. The IAMS can be factory recalibrated in the field if desired.

The unit's environmental operating temperature range is -20° C to 60° C. DIN rail mounting saves time and panel space. The units are equipped with mounting feet to attach to top hat profile rail according to EN50022 – 35 x 7.5 and 35 x 15.

SAFETY SUMMARY

All safety related regulations, local codes and instructions that appear in the literature or on equipment must be observed to ensure personal safety and to prevent damage to either the instrument or equipment connected to it. If equipment is used in a manner not specified by the manufacturer, the protection provided by the equipment may be impaired.

DIMENSIONS In inches (mm)

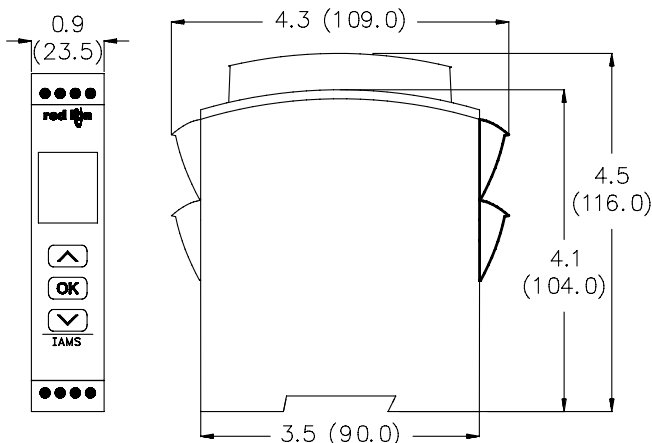

CAUTION: Risk of Danger
 Read complete instructions prior to installation and operation of the unit.



CAUTION: Risk of electric shock.



INSTALLATION

WARNING

To keep the safety distances, the relay contacts on the devices must not be connected to both hazardous and non-hazardous voltages at the same time.

The IAMS devices must be mounted on a DIN rail according to DIN 46277.

TABLE OF CONTENTS

Ordering Information	2	Wiring the Unit	4
General Specifications	2	Reviewing the Front Buttons and Display . . .	6
Accessories	3	Programming the Unit	6
Installing the Unit	4	Programming Overview	11
Installing the Programming Module	4		

ORDERING INFORMATION

Unit Part Numbers

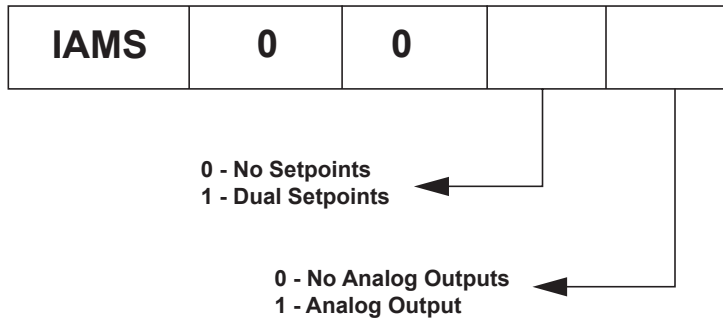

PGMMOD00 - Programming/Display Module for IAMS
 (Requires one to program a unit, or a series of units.)

GENERAL SPECIFICATIONS

1. **DISPLAY:** See Display/ Programming Module
2. **POWER:**
 AC Power: 21.6 to 253 VAC, 50/60 Hz
 DC Power: 19.2 to 300 VDC,
3. **CONSUMPTION:** ≤2.5 W
4. **FUSE:** 400 mA SB/250 VAC
5. **ISOLATION:** Between input, supply and outputs - 2.3 kVAC/250 VAC
6. **INPUTS:**

Current Input:
 Programmable Ranges: 0 to 20 and 4 to 20 mA DC
 Measurement range: -1 to 25 mA
 Input resistance: Nom. 20 Ω + PTC 50 Ω
 Sensor error detection: 4 to 20 loop break, yes
 Supply Voltage: 16-25 VDC, 20 mA max (Terminal 43 and 44)

Voltage Input:
 Programmable Ranges: 0 to 1, 0.2 to 1, 0 to 5, 1 to 5, 1 to 10, and 2 to 10 VDC
 Measurement range: -20 mV to 12 VDC
 Input resistance: Nom. 10 MΩ

Thermocouple Inputs:
 Thermocouple Type: B, E, J, K, L, N, R, S, T, U, W3, W5, and LR
 Cold Junction Compensation: via internally mounted sensor < ±1.0 °C
 Sensor Error Detection: All TC types, yes
 Sensor Error Current: When detecting 2 µA, otherwise 0 µA

TYPE	MIN. VALUE	MAX. VALUE	STANDARD
B	+400 °C	+1820 °C	IEC 60584-1
E	-100 °C	+1000 °C	IEC 60584-1
J	-100 °C	+1200 °C	IEC 60584-1
K	-180 °C	+1372 °C	IEC 60584-1
L	-200 °C	+900 °C	DIN 43710
N	-180 °C	+1300 °C	IEC 60584-1
R	-50 °C	+1760 °C	IEC 60584-1
S	-50 °C	+1760 °C	IEC 60584-1
T	-200 °C	+400 °C	IEC 60584-1
U	-200 °C	+600 °C	DIN 43710
W3	0 °C	+2300 °C	ASTM E988-90
W5	0 °C	+2300 °C	ASTM E988-90
LR	-200 °C	+800 °C	GOST 3044-84

RTD, Linear Resistance, Potentiometer Inputs

RTD Types: Pt10, Pt20, Pt50, Pt100, Pt200, Pt250, Pt300, Pt400, Pt500, Pt1000, Ni50, Ni100, Ni120, and Ni1000

INPUT TYPE	MIN. VALUE	MAX. VALUE	STANDARD
Pt100	-200 °C	+850 °C	IEC60751
Ni100	-60 °C	+250 °C	DIN 43760
Lin. R	0 Ω	10000 Ω	-
Potentiometer	10 Ω	100 kΩ	-

Cable Resistance per wire: RTD, 50 Ω max.

Sensor Current: RTD, Nom. 0.2 mA

Sensor Error Detection: RTD, yes

Short Circuit Detection: RTD, < 15 Ω

7. STEP RESPONSE TIME: (0 to 90% or 100 to 10%)

Temperature input: ≤ 1 sec

Current/Voltage input: ≤ 400 msec

8. ACCURACY: The greater of the general and basic values.

GENERAL VALUES		
Input Type	Absolute Accuracy	Temperature Coefficient
All	≤ ±0.1% of span	≤ ±0.1% of span/°C

BASIC VALUES		
Input Type	Basic Accuracy	Temperature Coefficient
mA	≤ ±4 µA	≤ ±0.4 µA/°C
Volt	≤ ±20 µV	≤ ±2 µV/°C
Pt100	≤ ±0.2 °C	≤ ±0.01 °C/°C
Lin. R	≤ ±0.1 Ω	≤ ±0.01 Ω/°C
Potentiometer	≤ ±0.1 Ω	≤ ±0.01 Ω/°C
TC Type: E, J, K, L, N, T, U	≤ ±1 °C	≤ ±0.5 °C/°C
TC Type: B, R, S, W3, W5, LR	≤ ±2 °C	≤ ±0.2 °C/°C

9. CALIBRATION TEMPERATURE: 20 to 28 °C

10. RELAY OUTPUTS: Dual Form A. Contacts rated at 2 A AC or 1 A DC

Hysteresis: 0.1 to 25 % (1 to 2999 display counts)

On and off delay: 0 to 3600 sec

Sensor Error Detection: Break / Make / Hold

Max. Voltage: 250 Vrms

Max. Current: 2 A AC or 1 ADC

Max. Power: 500 VA

11. ANALOG OUTPUT:

Current Output:

Signal Range (Span): 0 to 20 mA

Programmable Measurement Range: 0 to 20, 4 to 20, 20 to 0, and 20 to 4 mA

Load Resistance: 800 Ω max.

Output Compliance: 16 VDC max.

Load Stability: = 0.01 % of span, 100 Ω load

Sensor Error Detection: 0 / 3.5 mA / 23 mA / none

Output Limitation: For 4 to 20 and 20 to 4 mA signals - 3.8 to 20.5 mA

For 0 to 20 and 20 to 0 mA signals - 0 to 20.5 mA

Current Limit: = 28 mA

Voltage Output:

Signal Range: 0 to 10 VDC

Programmable Signal Ranges: 0 to 1, 0.2 to 1, 0 to 10, 0 to 5, 1 to 5, 2 to 10, 1 to 0, 1 to 0.2, 5 to 0, 5 to 1, 10 to 0, and 10 to 2 V

Load: 500 K Ω min

12. ENVIRONMENTAL CONDITIONS:

Operating Temperature: -20 to +60 °C

Operating and Storage Humidity: 95% relative humidity (non-condensing)

13. CERTIFICATIONS AND COMPLIANCES:

ELECTROMAGNETIC COMPATIBILITY:

EMC 2004/108/EC Emission and Immunity EN 61326

EMC Immunity Influence <± 0.5% of span

Extended EMC Immunity: NAMUR NE 21,

A criterion, burst <± 1% of span

SAFETY

LVD 2006/95/EC

EN 61010-1

Factory Mutual Approved, Report #3034432, FM 3600, 3611, 3810, and ISA 82.02.01

FM, applicable in: Class I, Div. 2, Group A, B, C, D

Class I, Div. 2, Group IIC

Zone 2

Max. ambient temperature for T5 60°C

UL Listed, File # E324843, UL508, CSA C22.2 No. 14-M95

LISTED by Und. Lab. Inc. to U.S. and Canadian safety standards

Refer to the EMC Installation Guidelines section of this bulletin for additional information.

14. CONSTRUCTION: IP 50/IP20 Touch Safe, case body is black high impact plastic. Pollution Degree 1.

15. CONNECTIONS: High compression cage-clamp terminal block. Use 60/75°C copper conductors only.

Wire strip length: 0.3" (7.5 mm)

Wire gage: 26 – 14 AWG stranded wire

Torque: 4.5 inch-lbs (0.5 N-m) max

16. WEIGHT: 5 oz (145 g)

5.6 oz (160 g) with programming module

ACCESSORY



Display/ Programming Module

The module easily connects to the front of the IAMS and is used to enter or adjust the programming of the module. For applications that require more than one IAMS, the same programming module can be used to program multiple units. In fact, it can store the configuration from one module and download the same configuration to another module. When the module is not being used for programming, it can provide a display of the process data and status.

Display: LCD display with 4 lines; line 1 is 0.2" (5.5 mm) and displays the input signal, line 2 is 0.13" (3.33 mm) and displays units, line 3 is 0.13" (3.33 mm) and displays analog output or tag number, line 4 shows communication and relay status

Programming Mode: Three push buttons combined with a simple and easily understandable menu structure and help text guides you effortlessly through the configuration steps. The actual configuration/set-up will be explained in the Programming Section.

Password Protection: Programming access may be blocked by assigning a password. The password is saved in the IAMS to guard against unauthorized modifications to the configuration. A default password of "2008" allows access to all configuration menus.

1.0 INSTALLING THE UNIT

The IAMS is designed to mount to a top hat profile DIN rail. The unit should be installed in a location that does not exceed the maximum operating temperature and provides good air circulation. Placing the unit near devices that generate excessive heat should be avoided.

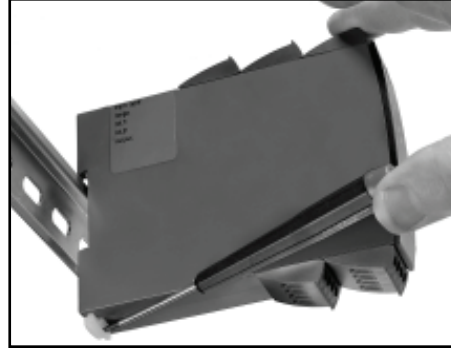

2.0 INSTALLING THE PROGRAMMING MODULE

The PGMMOD, Programming/Display Module is designed to connect to the front of the IAMS. Insert the top of the programming module first, then allow the bottom to lock into the IAMS.

When programming is complete, leave the programming module in place to display the process data or press the release tab on the bottom of the programming module.

3.0 WIRING THE UNIT

WIRING OVERVIEW

Electrical connections are made via screw-clamp terminals located on the sides of the unit. All conductors should conform to the unit's voltage and current ratings. All cabling should conform to appropriate standards of good installation, local codes, and regulations. It is recommended that power supplied to the unit (DC or AC) be protected by a fuse or circuit breaker.

When wiring the unit, compare the numbers on the terminal blocks against those shown in wiring drawings for proper wire position. Insert the wire under the correct screw-clamp terminal and tighten until the wire is secure. (Pull wire to verify tightness.)

EMC INSTALLATION GUIDELINES

Although this unit is designed with a high degree of immunity to ElectroMagnetic Interference (EMI), proper installation and wiring methods must be followed to ensure compatibility in each application. The type of the electrical noise, source or coupling method into the unit may be different for various installations. The unit becomes more immune to EMI with fewer I/O connections. Cable length, routing, and shield termination are very important and can mean the difference between a successful installation or troublesome installation.

Listed below are some EMC guidelines for successful installation in an industrial environment.

1. Use shielded (screened) cables for all Signal and Control inputs. The shield (screen) pigtail connection should be made as short as possible. The connection point for the shield depends somewhat upon the application. Listed below are the recommended methods of connecting the shield, in order of their effectiveness.
 - a. Connect the shield only at the rail where the unit is mounted to earth ground (protective earth).
 - b. Connect the shield to earth ground at both ends of the cable, usually when the noise source frequency is above 1 MHz.
 - c. Connect the shield to common of the unit and leave the other end of the shield unconnected and insulated from earth ground.

2. Never run Signal or Control cables in the same conduit or raceway with AC power lines, conductors feeding motors, solenoids, SCR controls, and heaters, etc. The cables should be run in metal conduit that is properly grounded. This is especially useful in applications where cable runs are long and portable two-way radios are used in close proximity or if the installation is near a commercial radio transmitter.
3. Signal or Control cables within an enclosure should be routed as far away as possible from contactors, control relays, transformers, and other noisy components.
4. In extremely high EMI environments, the use of external EMI suppression devices, such as ferrite suppression cores, is effective. Install them on Signal and Control cables as close to the unit as possible. Loop the cable through the core several times or use multiple cores on each cable for additional protection. Install line filters on the power input cable to the unit to suppress power line interference. Install them near the power entry point of the enclosure. The following EMI suppression devices (or equivalent) are recommended:

Ferrite Suppression Cores for signal and control cables:

Fair-Rite # 0443167251 (RLC #FCOR0000)

TDK # ZCAT3035-1330A

Steward #28B2029-0A0

Line Filters for input power cables:

Schaffner # FN610-1/07 (RLC #LFIL0000)

Schaffner # FN670-1.8/07

Corcom #1VR3

Note: Reference manufacturer's instructions when installing a line filter.

5. Long cable runs are more susceptible to EMI pickup than short cable runs. Therefore, keep cable runs as short as possible.
6. Switching of inductive loads produces high EMI. Use of snubbers across inductive loads suppresses EMI.
Snubber: RLC#SNUB0000.

3.1 POWER WIRING

Supply:

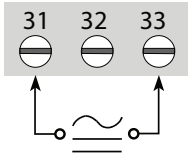

Note: For DC power connections, there are no polarity concerns.

3.2 INPUT SIGNAL WIRING

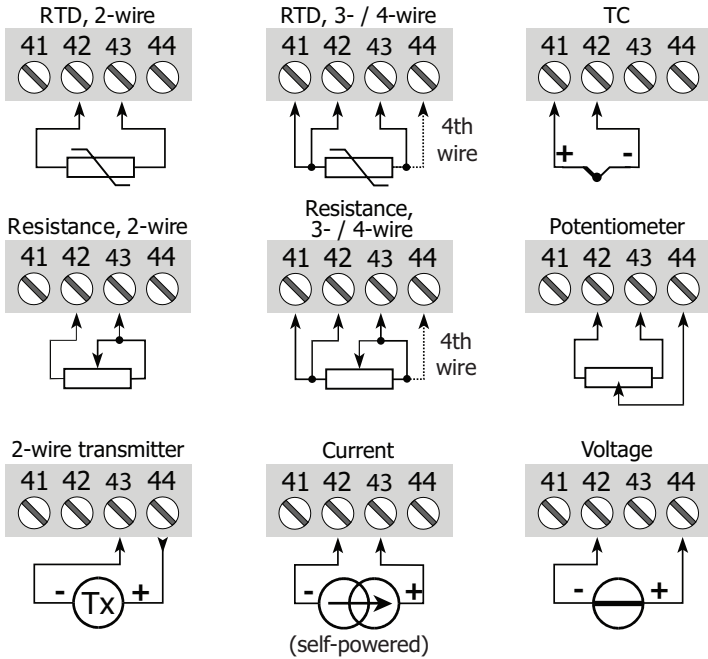

3.3 ANALOG OUTPUT WIRING

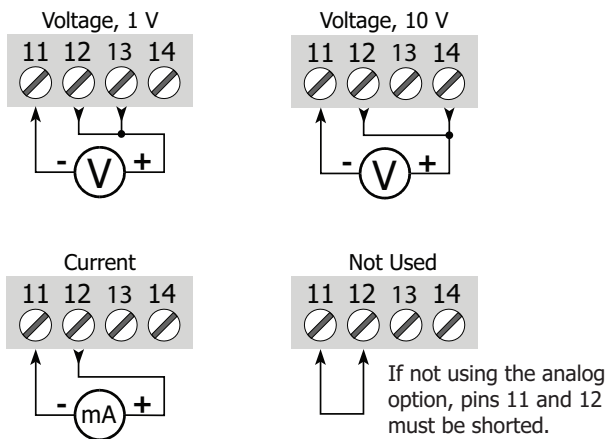

3.4 SETPOINT OUTPUT WIRING

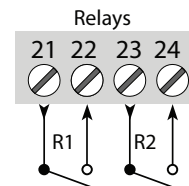

4.0 REVIEWING THE FRONT BUTTONS AND DISPLAY



DISPLAY: Total of four lines.

	Display Mode	Programming Mode
Line 1	Displays input signal	Shows the selected parameter value
Line 2	Displays input units	Shows the selected parameter
Line 3	Displays output signal	Shows scrolling help text
Line 4	Displays communication and relay status	Shows communication and relay status

PUSH BUTTONS: Configuration of the unit is by the use of the three function keys. These keys are only active in the programming mode.

- ∧ - increases the numerical value or choose the next selection
- OK - Enters programming mode, saves the chosen value and proceeds to the next selection
- ∨ - decreases the numerical value or choose the previous selection

5.0 PROGRAMMING THE UNIT

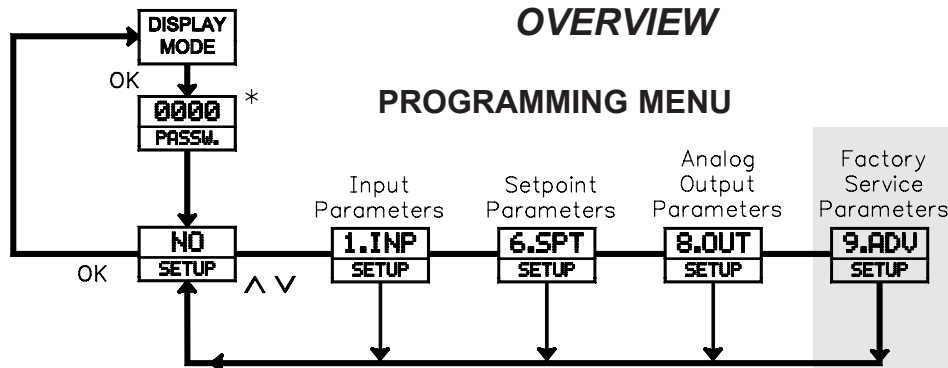

Warning: Save all programming changes before entering 9.ADV SETUP. Do this by exiting the Program Mode at the NO SETUP prompt and then reentering.

* If password is enabled.

STEP BY STEP PROGRAMMING INSTRUCTIONS:

PROGRAMMING MODE ENTRY (OK KEY)

A programming module, PGMMOD00 is required to program the unit. The programming mode is entered by pressing the **OK** key. If the password protection is enabled, entry of the password is required to gain access. If the password protection is disabled, direct access to programming will occur.

MENU ENTRY (ARROW & OK KEYS)

Upon entering the programming mode (set-up), the arrow keys will index between the programming modules. Select the desired module, press the **OK** key enter the module programming.

PARAMETER SELECTION AND ENTRY (ARROW & OK KEYS)

In each of the Programming Modules are parameters that can be configured to the desired action for a specific application. Each parameter has a list of selections or a numeric value that can be entered. The parameters are displayed on line #2 and the selection is on line #1. The arrow keys will move through the selection list or increase or decrease the numeric values. Once the selection or numeric value is set to the desired action, press the **OK** key to enter the data and move to the next parameter.

PROGRAMMING MODE EXIT (ARROW & OK KEYS)

After completing a programming module loop, the display will return to the set-up position. At this time additional programming modules can be selected for programming or the selection of "NO" can be entered. Entering "NO" will exit the Programming Mode, save any changes, and enable the Display Mode. (If power loss occurs before returning to the display mode, verify recent parameter changes.)

Note: The unit will return to the Display Mode from any menu after 1 minute without a key press or by pressing and holding the OK key for 2 seconds. In these cases, verify recent parameter changes.

FAST SET MENU

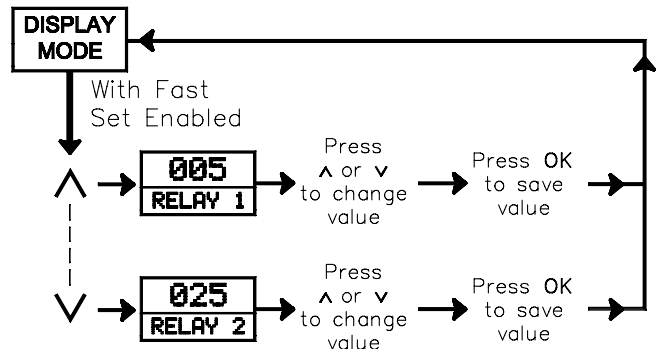

FAST SETPOINT MODE

- ∧ - displays setpoint 1 and increases the shown setpoint value
- OK - saves the changed setpoint value and returns to the Display Mode (Holding for 2 seconds returns to the Display Mode without saving.)
- ∨ - displays setpoint 2 and decreases the shown setpoint value

5.1 MODULE 1 - SIGNAL INPUT PARAMETERS

PARAMETER MENU - VOLTAGE, CURRENT AND POTENTIOMETER

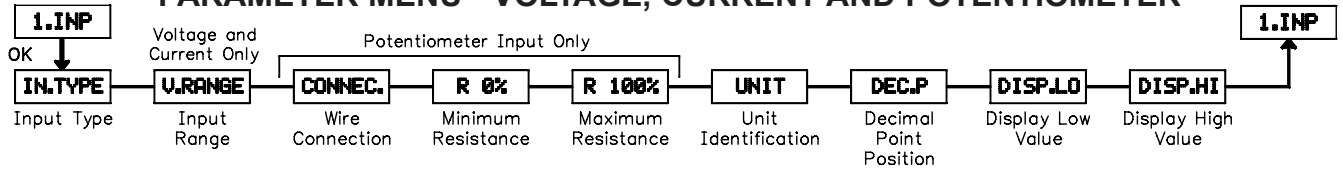

PARAMETER MENU - TEMPERATURE

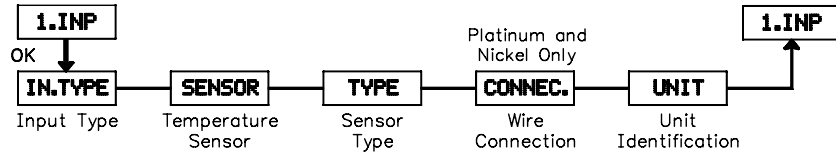

INPUT TYPE (IN TYPE)

VOLT
INTYPE

VOLT CURR LIN.R
POTM TEMP

Select the appropriate Input Type for the application.

Note: Changing the input parameters may affect the setpoint and/or analog programming.

MAXIMUM RESISTANCE (R 100%)

2500
R 100%

0.0 to 9999

Enter the high resistance value.

The next five parameters apply to the voltage, current, linear resistance and potentiometer input types.

INPUT TYPE (VOLT)

VOLT
INTYPE

If input type is selected for voltage, the following parameters appear.

VOLTAGE RANGE (U.RANGE)

2-10 0-1 0-5 0-10
U.RANGE 0.2-1 1-5 2-10

Select the appropriate Voltage Range that corresponds to the external signal. This selection should be high enough to avoid input signal overload but low enough for the desired input resolution.

INPUT TYPE (CURR)

CURR
INTYPE

If input type is selected for current, the following parameters appear.

CURRENT RANGE (I.RANGE)

4-20 0-20 4-20
I.RANGE

Select the appropriate Current Range that corresponds to the external signal. This selection should be high enough to avoid input signal overload but low enough for the desired input resolution.

INPUT TYPE (LIN.R)

LIN.R
INTYPE

If input type is selected for linear resistance, the following parameters appear.

WIRE CONNECTION (CONNEC.)

3W 2W 3W 4W
CONNEC.

Select the wires the sensor or signals has to connect to the unit.

MINIMUM RESISTANCE (R 0%)

0 0.0 to 9996
R 0%

Enter the low resistance value.

UNIT IDENTIFICATION (UNIT)

UNIT
%

Select one of the 69 available units as listed below.

°C	hp	kW	mA	pH
°F	hPa	kWh	mbar	rPm
%	Hz	l	mils	s
A	in	l/h	min	S
bar	in/h	l/min	mm	t
cm	in/min	l/s	mm/s	t/h
ft	in/s	m	mol	uA
ft/h	ips	m/h	mPa	um
ft/min	K	m/min	mV	uS
ft/s	kA	m/s	MW	U
g	kø	m/s ²	MWh	W
gal/h	kJ	m ³	N	Wh
gal/min	kPa	m ³ /h	Ohm	yd
GW	kV	m ³ /min	Pa	

DECIMAL POINT (DEC.P)

111.1
DEC.P

1111 111.1
11.11 1.111

Select the appropriate decimal point location.

DISPLAY LOW (DISP.LO)

0.0
DISP.LO

-199.9 to 999.9

Enter the low display value.

DISPLAY HIGH (DISP.HI)

1000
DISP.HI

-199.9 to 999.9

Enter the high display value.

The remaining parameters in this module apply to temperature input type only.

INPUT TYPE (TEMP)

TEMP
INTYPE

If input type is selected for temperature, the following parameters appear.

TEMPERATURE SENSOR (SENSOR)

Ni
SENSOR

Pt, Ni, or TC

Select the appropriate temperature sensor.

RTD -Select the appropriate RTD sensor.

TYPE: Pt10 Pt20 Pt50 Pt100
Pt200 Pt250 Pt300
Pt400 Pt500 Pt1000
WIRE CONNECTION: 2W 3W 4W

NICKEL SENSORS -Select the appropriate Nickel sensor.

TYPE: Ni50 Ni100
Ni120 Ni1000
WIRE CONNECTION: 2W 3W 4W

THERMOCOUPLE -Select the appropriate Thermocouple sensor.

TYPE: TC.B TC.E TC.J TC.K TC.L
TC.N TC.R TC.S TC.T TC.U
TC.W3 TC.W5 TC.Lr

UNIT IDENTIFICATION (UNIT)

°C
UNIT

°F or °C

Select the appropriate unit for the temperature being displayed.

5.2 MODULE 6 - SETPOINT PARAMETERS (REQUIRES SETPOINT OPTION)

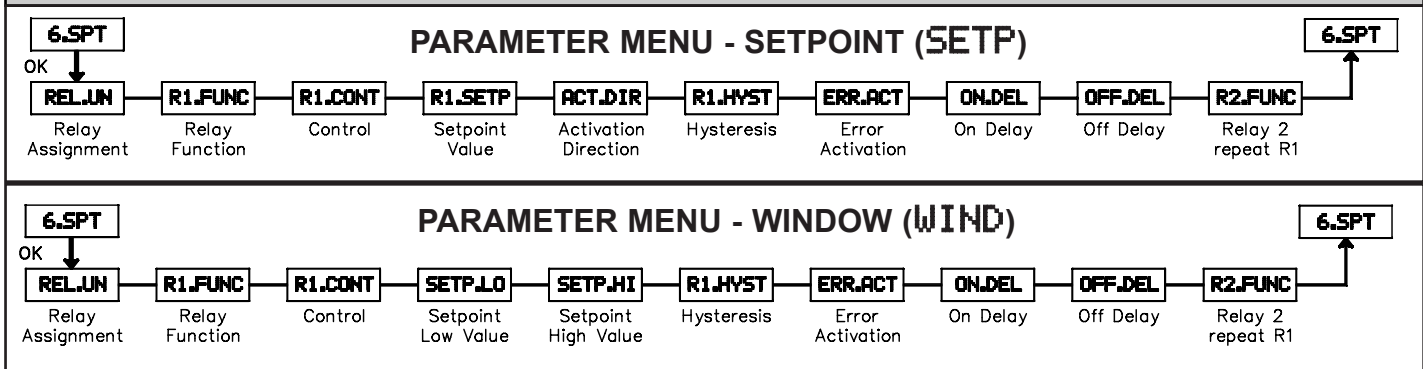

RELAY ASSIGNMENT (REL.UN)

DISP
REL.UN

DISP or PERC

Select relay assignment to display units or percent of the input.

RELAY 1 FUNCTION (R1.FUNC)

SETP
R1.FUNC

SETP WIND ERR
POW OFF

Select how relay 1 is to function. For SETP the relay is controlled by setpoint one. Select WIND and the relay is controlled by 2 setpoints. For ERR the relay indicates sensor alarm only. Select POW and the relay indicates power status. For OFF the relay is disabled.

RELAY 1 FUNCTION (SETP)

SETP
R1.FUNC

If the relay function is selected for setpoint, the following parameters appear.

RELAY 1 CONTROL (R1.CONT)

N.O.
R1.CONT

N.O. or N.C.

Select relay 1 operation, normally open or normally closed.

RELAY 1 SETPOINT VALUE (R1.SETP)

50.0
R1.SETP

-200 to 850.0

Enter the relay 1 setpoint value.

ACTIVATION DIRECTION (ACT.DIR)

INCR
ACT.DIR

INCR or DECR

Select the direction relay 1 should activate, increasing signal or decreasing signal.

RELAY 1 HYSTERESIS (R1.HYST)

1.0
R1.HYST

0.1 to 262.5

Enter relay 1 hysteresis value.

RELAY 1 ERROR ACTIVATION (ERR.ACT)

NONE
ERR.ACT

HOLD, CLOS, OPEN, and NONE

Select relay 1 error mode action.

RELAY 1 ON DELAY (ON.DEL)

0
ON.DEL

0 to 3600

Enter relay 1 On Delay Time.

RELAY 1 OFF DELAY (OFF.DEL)

0
OFF.DEL

0 to 3600

Enter relay 1 Off Delay Time.

RELAY 1 FUNCTION (WIND)

WIND
R1.FUNC

If the relay function is selected for window, the following parameters appear.

RELAY 1 CONTROL (R1.CONT)

0111
R1.CONT

0111 or C111

Select relay 1 contact to be open inside the window or closed in the window.

SETPOINT LOW VALUE (SETP.LO)

60.0
SETP.LO

-200 to 849.9

Enter the window's low value.

SETPOINT HIGH VALUE (SETP.HI)

60.0
SETP.HI

-199.9 to 850.0

Enter the window's high value.

RELAY WINDOW HYSTERESIS (R1.HYST)

1.0
R1.HYST

0.1 to 262.5

Set the window's hysteresis value.

RELAY 1 ERROR ACTIVATION (ERR.ACT)

NONE
ERR.ACT

HOLD, CLOS, OPEN, and NONE

Select relay 1 error mode action.

RELAY 1 ON DELAY (ON.DEL)

0
ON.DEL

0 to 3600

Enter relay 1 On Delay Time.

RELAY 1 OFF DELAY (OFF.DEL)

0
OFF.DEL

0 to 3600

Enter relay 1 Off Delay Time.

RELAY 1 FUNCTION (ERR)

ERR
R1.FUNC

If the relay function is selected for error mode, the following parameters appear.

RELAY 1 ERROR ACTIVATION (ERR.ACT)

OPEN
ERR.ACT

CLOS OPEN

Select relay 1 error mode action.

The POW and OFF selection have no programming capabilities.

For Relay 2, repeat the steps listed for Relay 1.

5.3 MODULE 8 - ANALOG OUTPUT PARAMETERS (REQUIRES ANALOG OUTPUT OPTION)

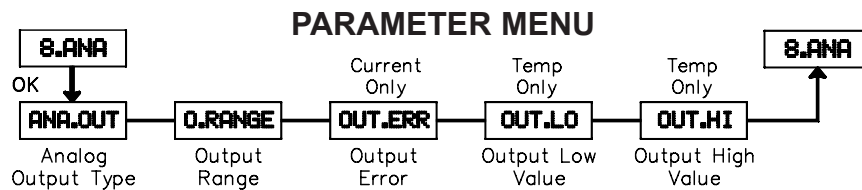

ANALOG OUTPUT TYPE (ANA.OUT)

CURR
ANA.OUT

VOLT or CURR

Select either Voltage or Current output.

OUTPUT LOW VALUE (OUT.LO) For TEMP only

0.0
OUT.LO

-200 or 849.9

Enter the value for the output Low Value.

OUTPUT RANGE (O.RANGE)

0-10
O.RANGE

Select the appropriate range based on the analog output type selected.

VOLTAGE -Select the appropriate voltage range.

RANGE: 0-1, 0.2-1, 0-5, 1-5, 1-10, or 2-10

CURRENT -Select the appropriate current range.

RANGE: 0-20, 4-20, 20-0, or 20-4

OUTPUT HIGH VALUE (OUT.HI) For TEMP only

150.0
OUT.HI

-199 or 850.0

Enter the value for the output High Value.

OUTPUT ERROR (OUT.ERR) For CURR only

23mA
OUT.ERR

NONE, 0mA, 3.5mA, or 23mA

This parameter is only available if the analog output type is selected for current. Select the proper Error action, if needed.

5.4 MODULE 9 - ADVANCED PARAMETERS

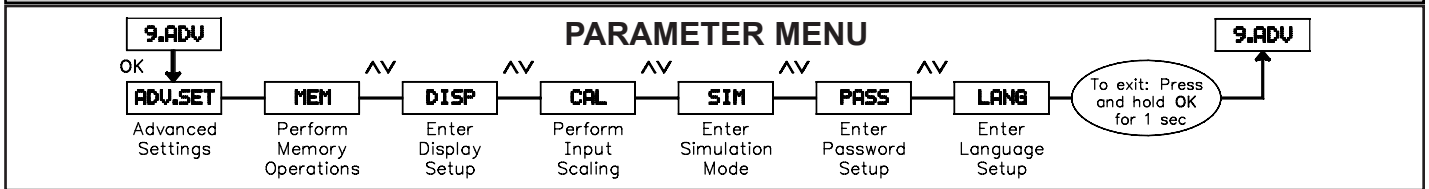

ADVANCED SETTING (ADV.SET)

MEM
ADV.SET

MEM DISP CAL
SIM PASS LANG

Select the advanced setting menu to make the desired change.

HIGH CALIBRATION POINT VALUE (High Input Signal)

97.8
°C

-200 to 850.0

Apply the high input signal, then enter the value for the High Value Point.

USE PROCESS CALIBRATION VARIABLES (USE.CAL)

YES
USE.CAL

NO or YES

Use Process Calibration Variables.

ADVANCED SETTING (MEMORY)

MEM
ADV.SET

If the advanced setting is selected for memory, the following parameter appears.

MEMORY SETTING (MEMORY)

SAVE
MEMORY

LOAD or SAVE

Select save to save unit set-up to the display module or select load to download saved set-up to the unit.

ADVANCED SETTING (DISP)

DISP
ADV.SET

If the advanced setting is selected for display, the following parameters appear.

LCD CONTRAST (CONTRA.)

3
CONTRA.

0 to 9

Select the desired Display Contrast.

LCD BACKLIGHT ADJUSTMENT (LIGHT)

9
LIGHT

0 to 9

Select the desired Display Backlight.

TAG NUMBER (TAGNO.)

TAGNO.

A to 9

Enter a custom 6 character device tag.

LINE 3 SET UP (LINE 3)

A.OUT
LINE 3

A.OUT or TAG

Select the proper display for Line 3.

ADVANCED SETTING (CAL)

CAL
ADV.SET

If the advanced setting is selected for calibration (applied input scaling), the following parameters appear as selected in the input setup. A temperature example is shown.

CALIBRATION LOW (CAL.LO)

No
CAL.LO

NO or YES

Calibrate the input low to the process value.

LOW CALIBRATION POINT VALUE (Low Input Signal)

2.0
°C

-200 to 850.0

Apply the low input signal, then enter the value for the Low Value Point.

CALIBRATION HIGH (CAL.HI)

NO
CAL.HI

NO or YES

Calibrate the input high to the process value.

ADVANCED SETTING (SIM)

SIM
ADV.SET

If the advanced setting is selected for simulation, the following parameters appear.

INPUT SIMULATION (ENA.SIM)

No
ENA.SIM

YES or No

Enable Input Simulation.

INPUT SIMULATION VALUE (°C)

23.0
°C

-200 to 850.0

Enter the Input Simulation Value, as selected in the input setup.

RELAY SIMULATION (REL.SIM)

REL.SIM

Use the ▲ and ▼ to toggle between relay 1 and 2.

ADVANCED SETTING (PASS)

PASS
ADV.SET

If the advanced setting is selected for password, the following parameters appear.

PASSWORD PROTECTION (EN.PASS)

No
EN.PASS

YES or No

Enable Password protection.

ENTER NEW PASSWORD (NEW.PAS) *

0000
NEW.PAS

0000 to 9999

Enter New Password.

ENABLE FAST SET (EN.FAST)

YES
EN.FAST

YES or No

Enable fast set functionality of the setpoints. .

* Universal code 2008 will allow access to a locked unit.

ADVANCED SETTING (LANG)

LANG
ADV.SET

If the advanced setting is selected for LANGUAGE, the following parameter appears.

SELECT PROGRAMMING LANGUAGE (LANGUA)

UK
LANGUA

DE DK ES FR
IT SE UK

Set programming language.

IAMS PROGRAMMING QUICK OVERVIEW

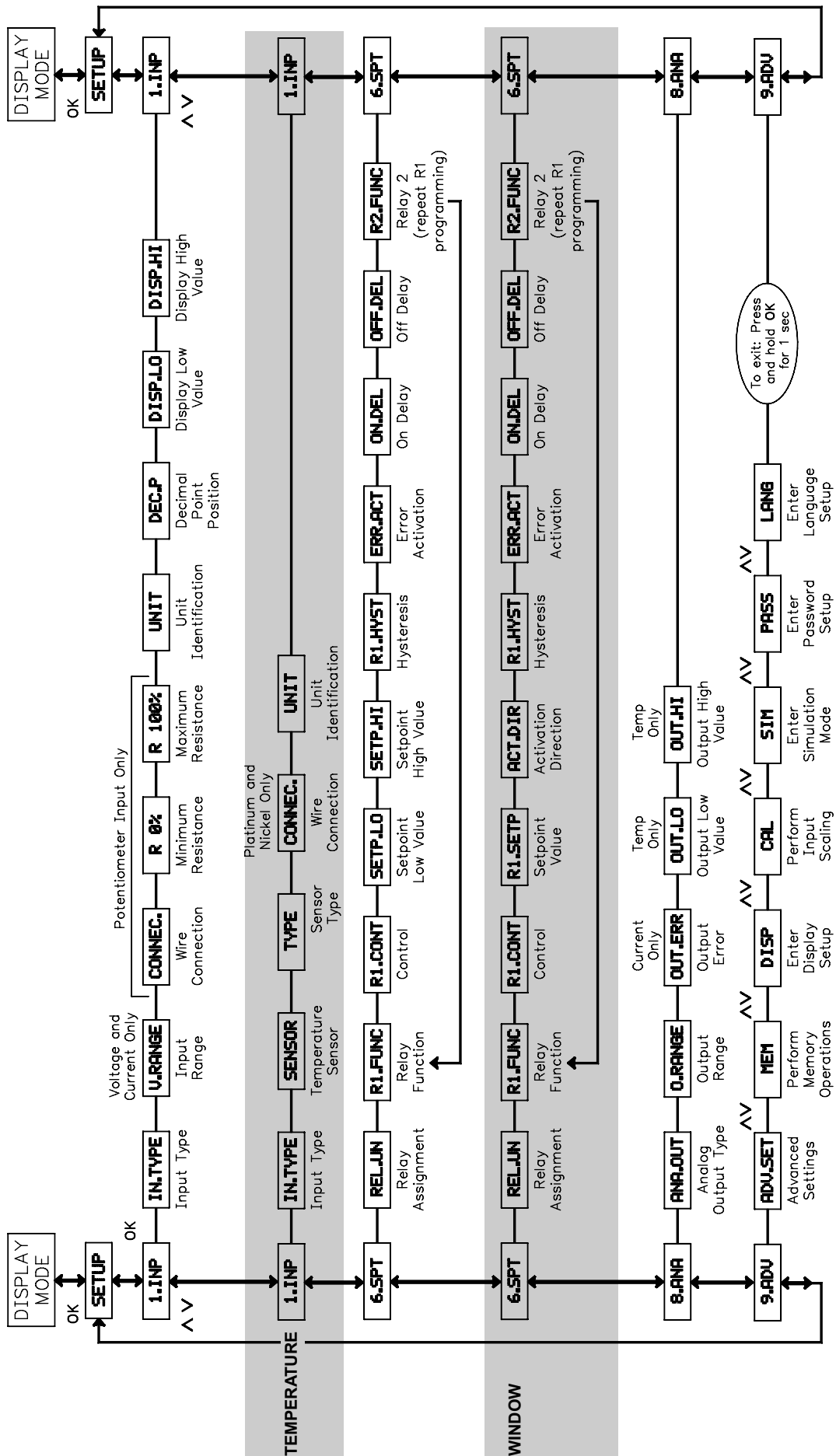

LIMITED WARRANTY

The Company warrants the products it manufactures against defects in materials and workmanship for a period limited to two years from the date of shipment, provided the products have been stored, handled, installed, and used under proper conditions. The Company's liability under this limited warranty shall extend only to the repair or replacement of a defective product, at The Company's option. The Company disclaims all liability for any affirmation, promise or representation with respect to the products.

The customer agrees to hold Red Lion Controls harmless from, defend, and indemnify RLC against damages, claims, and expenses arising out of subsequent sales of RLC products or products containing components manufactured by RLC and based upon personal injuries, deaths, property damage, lost profits, and other matters which Buyer, its employees, or sub-contractors are or may be to any extent liable, including without limitation penalties imposed by the Consumer Product Safety Act (P.L. 92-573) and liability imposed upon any person pursuant to the Magnuson-Moss Warranty Act (P.L. 93-637), as now in effect or as amended hereafter.

No warranties expressed or implied are created with respect to The Company's products except those expressly contained herein. The Customer acknowledges the disclaimers and limitations contained herein and relies on no other warranties or affirmations.

Red Lion Controls
20 Willow Springs Circle
York PA 17406
Tel +1 (717) 767-6511
Fax +1 (717) 764-0839

Red Lion Controls BV
Printerweg 10
NL - 3821 AD Amersfoort
Tel +31 (0) 334 723 225
Fax +31 (0) 334 893 793

Red Lion Controls AP
Unit 101, XinAn Plaza
Building 13, No.99 Tianzhou Road
ShangHai, P.R. China 200223
Tel +86 21 6113-3688
Fax +86 21 6113-3683