

Productivity3000™

Some call it a PAC.

Some call it a PLC.

We call it ... Productivity3000!

What's a PAC?

A programmable automation controller* (PAC) is a compact controller that combines the features and capabilities of a PC-based control system with that of a typical programmable logic controller (PLC).

PLC Feel

- Modular footprint
- Industrial reliability
- Wide array of I/O modules and system configurations

PC Power

- Large memory and high-speed processing
- High-level data handling and enterprise connectivity
- Extensive communications capability, multiple protocols and field networks

PACs are most often used for advanced machine control, process control, data acquisition and equipment monitoring.



Do these with ease

Large I/O Count

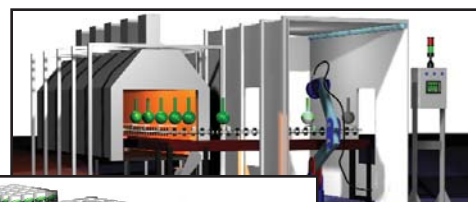

Multiple HMI

Data intensive

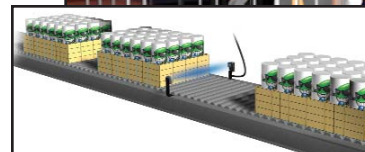

Integrated Drive Control

Communications Intensive

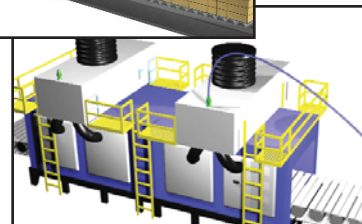

Process Control

With Productivity3000, you can get all the power you need for advanced applications. The great thing is, even if you don't need every bell and whistle, you still get an easy-to-use, super-flexible machine that costs less than most traditional PLCs.

Who wouldn't want a controller with seven built-in communication ports, easy local and remote I/O connection, USB or Ethernet programming and an integrated LCD display - and that's just the CPU!

More Productive when specifying

With Productivity3000, we're giving you advanced PAC features in a rugged PLC frame at a fraction of the cost compared to similarly equipped competitive products. Expansive communications capability built into the CPU is standard.

The FREE (\$495 value) full-featured ProductivitySuite software lets you try any hardware before you buy, plus no licenses to register, track or transfer.

PRACTICAL PRICES

More Productive when configuring

It's pretty simple - install the CPU in a rack, add local and/or remote I/O, even GS drives. There's no power budget to calculate or other restrictions - install any module in any rack.

Local and remote I/O ports are built into the CPU, as well as Ethernet and serial ports for device and network communications.

Once you've connected the components, let the system auto-discover the hardware configuration and save it in your project. Modules are then electronically keyed to prevent incorrect replacement.

SIMPLER MEANS LESS MISTAKES

More Productive when programming

Programming and commissioning a system with any type of automation controller is time consuming and can be a large part of your overhead. We've created powerful processes in the programming environment to reduce your development time.

Timesavers include combined ladder logic and function block programming; tag name database for easier documentation; task management that minimizes scan time; advanced instructions that simplify complex tasks, and an exhaustive HELP file that covers both hardware and software topics.

TIME IS MONEY

More Productive when troubleshooting

Run-time editing, hot-swappable I/O and onboard program documentation are tools that help you commission and troubleshoot your system more quickly and conveniently.

Use the built-in LCD display on the CPU and Remote Slave modules for system diagnostics, configuration and troubleshooting.

The patent-pending LCD interface built into each analog module shows you field signal levels without an external meter.

ADVANCED DIAGNOSTICS

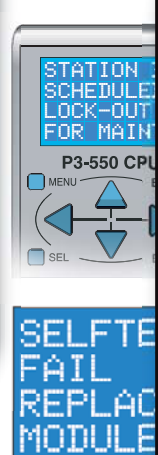
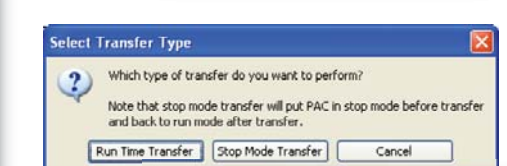
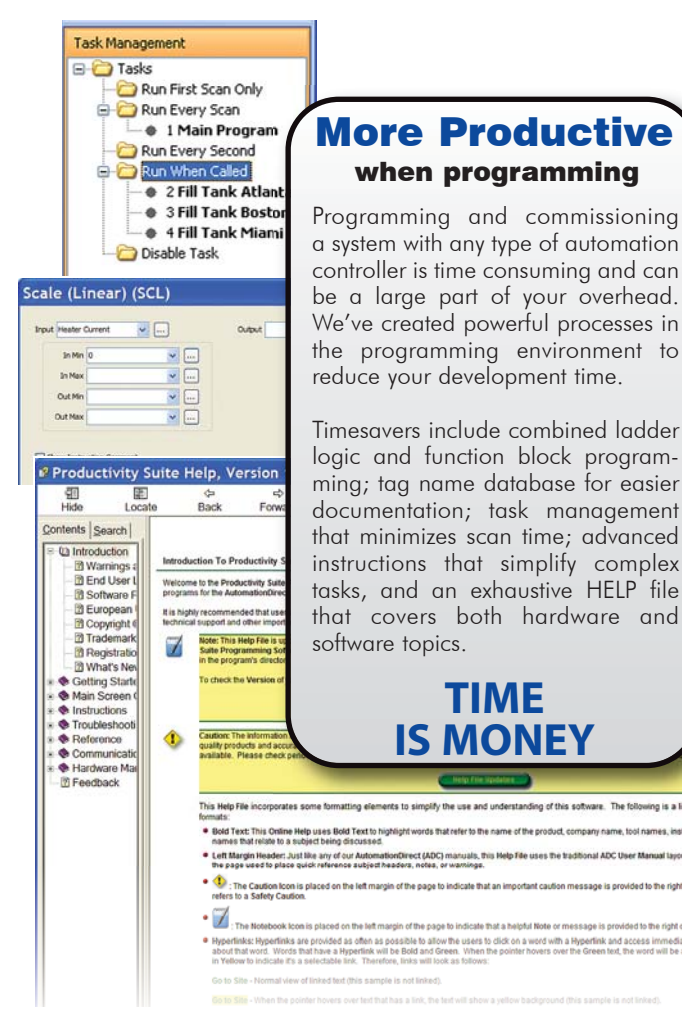
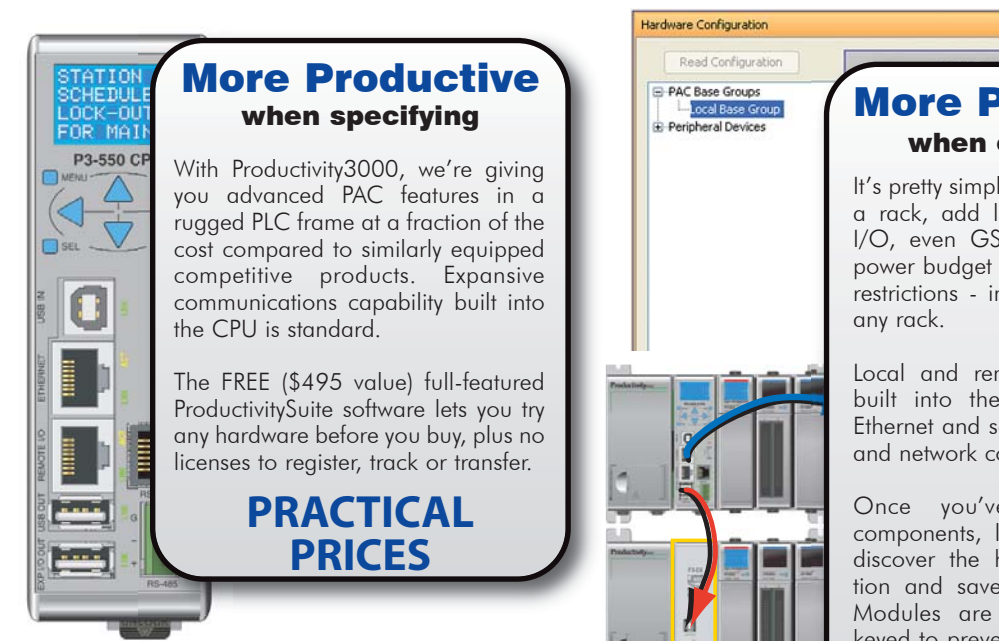

- AutomationDirect
- Company Info.
- PLCs
- Field I/O
- Software
- C-more & other HMI
- AC Drives
- AC Motors
- Power Transmiss.
- Steppers/Servos
- Motor Controls
- Proximity Sensors
- Photo Sensors
- Limit Switches
- Encoders
- Current Sensors
- Pressure Sensors
- Temp. Sensors
- Pushbuttons/Lights
- Process
- Relays/Timers
- Comm.
- Terminal Blocks & Wiring
- Power
- Circuit Protection
- Enclosures
- Tools
- Appendix
- Part Index

TOP 10 Hardware Highlights

- High-performance CPU with **50Mb memory**, fast scan time
- **Modular** rack-based footprint with 36 discrete and analog I/O option modules, up to 115K+ I/O
- Unmatched **built-in communications** capabilities, including local and remote I/O ports and networking
- Integrated **drive communications** over Ethernet
- **LCD display** on CPU and Remote Slave for configuration and diagnostics
- Patent-pending **LCD display on ALL analog modules** - Helpful in troubleshooting and reading process values
- **Hot-swappable I/O**
- No module placement restrictions - **any module in any slot**, any base
- **No power budget** limitations
- Optional I/O terminal blocks or easy ZIPLink **plug-and-play wiring**

and a two-year warranty to boot!

Field access with display on analog modules

The patent-pending LCD display gives you quick and easy access to field signal values - no need to drag out a multimeter or other measurement tool. Module and signal faults are also shown.

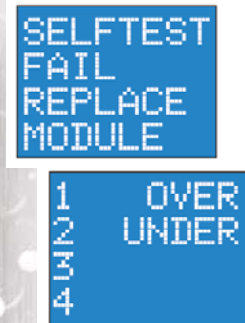

CPU just \$599, with 7 communication ports

50Mb of memory and fast scan time is just for starters - this CPU does the work of at least four or five pieces of hardware compared to other controllers. With its seven built-in communication ports, it does the usual CPU stuff like storing and running the program, plus -

- Plug-and-play USB programming (no converter cable needed)
- Tag database and program documentation storage (Program pre-loaded on PC not necessary)
- USB local I/O expansion (no local I/O expansion master module needed)
- Ethernet remote I/O expansion (no Ethernet remote master module needed)
- High-speed Ethernet port for HMI and peer-to-peer or enterprise networking (no Ethernet communications module needed)
- Two serial ports for peripheral device interface or controller networking (no serial port or ASCII module needed)
- USB data logging right from the CPU

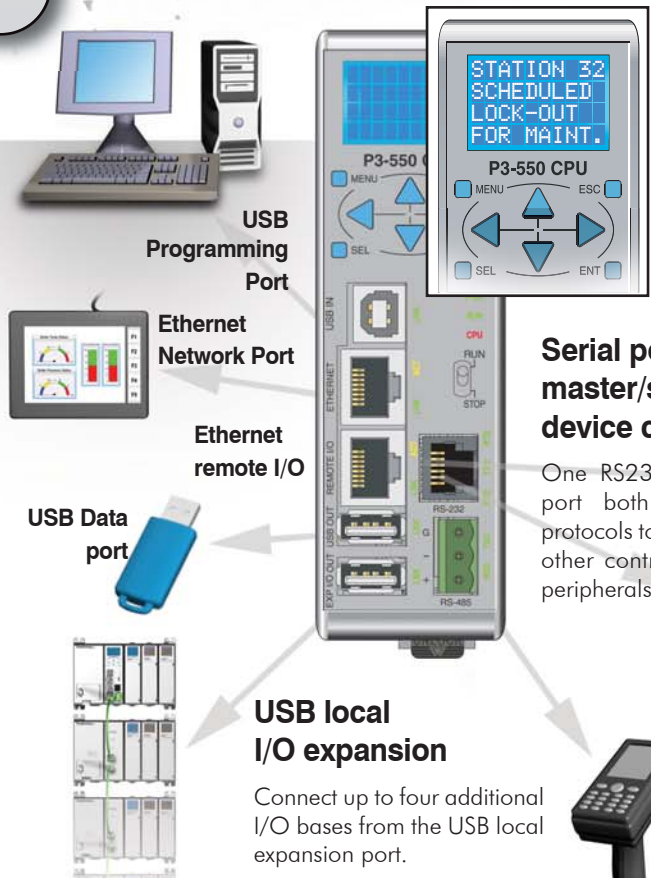

LCD display aids troubleshooting

The built-in display can show system alarms and information, or it can be configured to display user-defined messages with instructions triggered by the program.

Serial ports for master/slave or custom device connections

One RS232 and one RS485 serial port both support Modbus/ASCII protocols to connect to other controllers or peripherals.

Plenty of discrete and analog I/O modules

Over 35 I/O modules capture and control a wide range of field signals.

- Up to 64-point DC I/O
- Up to 16-point AC I/O, isolated or non-isolated
- Up to 16-point analog I/O; voltage, current or temperature

I/O modules can be placed in any slot, in any base - no need to remember special restrictions or calculate power budgets. And for critical systems, the hot-swap feature can save you from a catastrophe.

To make I/O wiring fast and easy, use our ZIPLink cables and connector modules.



Ethernet remote I/O like you've never seen

Connect up to 32 remote base groups from the Ethernet remote expansion port. Each remote group supports up to four additional local bases. Not that you'd want to, but you could end up with over 115,000 I/O!

The convenient USB port on the Remote Slave module lets you program and monitor from any remote I/O location; plus two serial ports support Modbus or custom protocol devices.

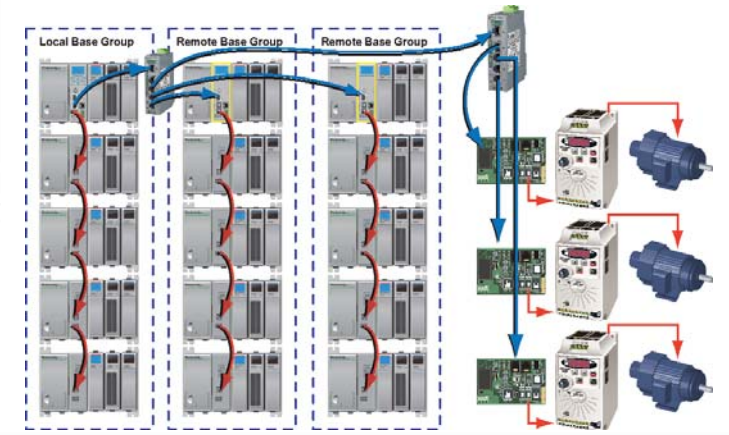

Easy drive integration

Drive-intensive applications are a snap with this remote I/O network. Connect up to 64 AutomationDirect GS series AC drives on the Ethernet remote I/O network (using GS-EDRV option cards). Units are auto-discovered when configuration update is requested - it's that easy.

- AutomationDirect
- Company Info.
- PLCs
- Field I/O
- Software
- C-more & other HMI
- AC Drives
- AC Motors
- Power Transmiss.
- Steppers/Servos
- Motor Controls
- Proximity Sensors
- Photo Sensors
- Limit Switches
- Encoders
- Current Sensors
- Pressure Sensors
- Temp. Sensors
- Pushbuttons/Lights
- Process
- Relays/Timers
- Comm.
- Terminal Blocks & Wiring
- Power
- Circuit Protection
- Enclosures
- Tools
- Appendix
- Part Index

TOP 10 Software Highlights

- Auto set-up and discovery of hardware
- Tag name database programming
- Task management
- Advanced "fill-in-the-blank" instructions
- Seamless Database connectivity
- Graphical HTML-based Help File
- Run-time editing
- Project file and user documentation stored in CPU
- USB data logging on the CPU
- Tag database export to C-more HMI

all in an intuitive Windows-based programming environment

All project files in CPU means it's not all Greek to you

With the ample memory in the CPU, there's plenty of room for the program, tag name database and all the program documentation. This means the helpful descriptions and comments are available to anybody with a PC and ProductivitySuite software. This can be pretty important when it's 1 a.m., the machine is down and you're the one that has to look at the program and figure out what's wrong.

Task management boosts program speed and efficiency

The Task Manager helps organize program code and execute it for maximum speed and efficiency. Create functional tasks, name them and schedule their execution frequency - every scan, every second, or when called. A "First Scan only" task lets you initialize values and conditions. Store specialized tasks that help debug and troubleshoot in the Disabled Tasks section.

Full-featured ProductivitySuite software FREE (\$495 value)

The Productivity3000 is a brand-new controller, and we want everyone to see just how feature-packed it is and how productive it can make you. That's why we're offering the software for FREE (downloadable online) right now - check out the tools, instruction set and programming/debug environment that will let you configure and program a system in less time than you can imagine.

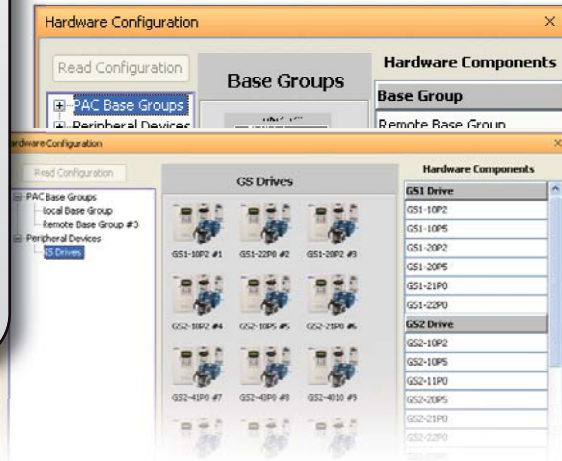

Hardware auto-discovery

One click is all it takes to detect and auto-configure the hardware connected to the system, including local and remote bases and I/O. GS drives are also automatically discovered when placed on the internal Ethernet network. This can save you literally hours and hours of setup time.

Or, configure the system offline by dragging and dropping bases and modules.

Advanced instructions are timesavers

There are so many time-saving instructions, and they all have one thing in common - their "fill-in-the-blank" approach makes it easy to configure even the more complex tasks that used to require a whole bunch of program code. Scaling, calculator-style math, statistics, send email, it goes on and on ...

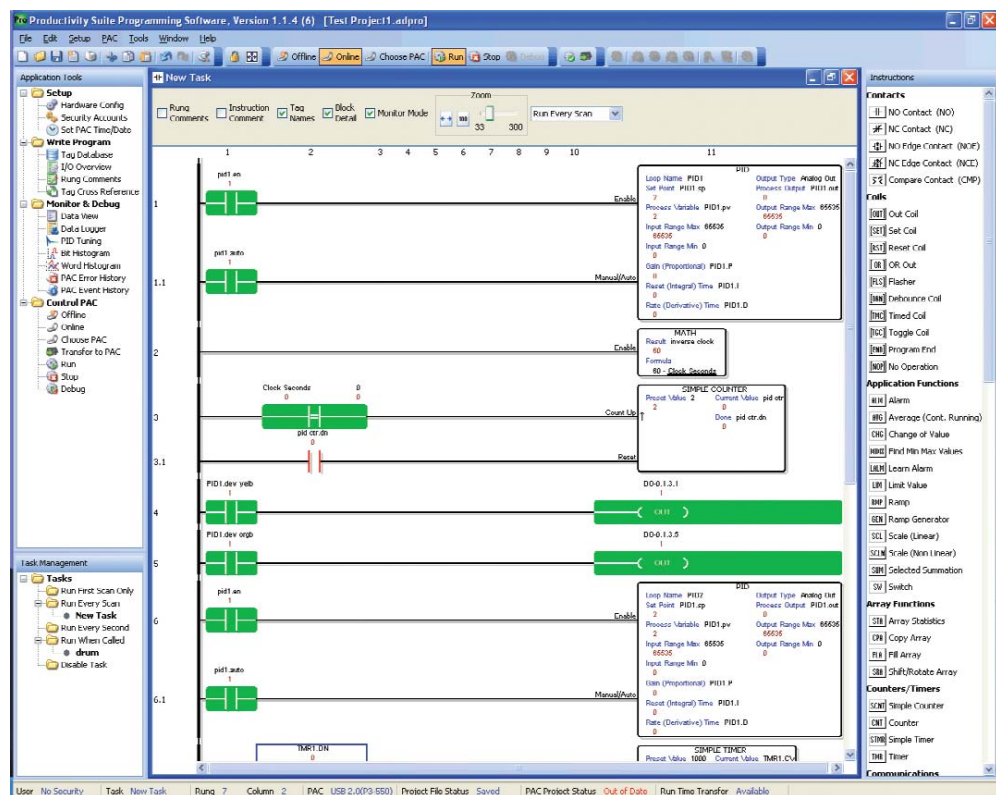

Tag name database is friendly and flexible

Data memory ranges in the Productivity3000 are not fixed by data type, which is more efficient because you have the freedom to define the data types you need instead of having wasted memory for ones you do not.

Also, a tag name database means no more confusing and ambiguous memory and I/O references - add descriptive names as you program or enter all the tags before you even write one line of code. The data is stored in true database format so you can search, filter and sort; import a .csv file or use the one created every time you save the project for importing into other databases.

Help File really does help

Detailed hardware and software information is at your fingertips with the exhaustive HTML-based Help file. From "Getting Started" to detailed program instruction descriptions, it's all there when you need it. Find the help you need on a specific topic quickly, and read only what's relevant to you at the time.



Easy data logging on CPU

Easily log data to a removable mass storage device (USB) on an event or time basis. Track up to 64 data values and system errors through the Data Logger tool. And the CPU will hold the data internally until an external device is replaced.



Run-time editing

Commissioning or troubleshooting a system can be less time-consuming if you can make program edits on the fly. Download edits to the CPU without pausing I/O updates or stopping/restarting the program. From melting rubber to making paper, you can keep your process running, avoiding downtime and product waste.

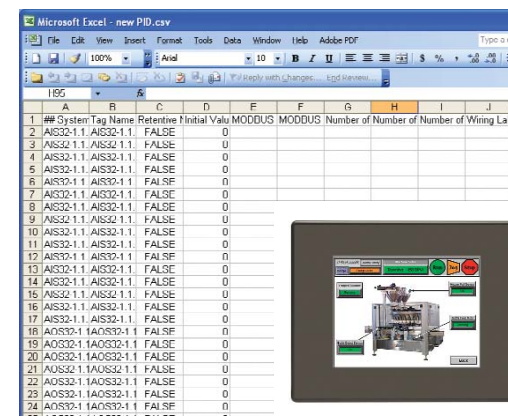
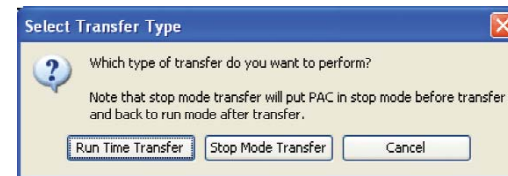

Seamless database connectivity

With the integrated DataWorx instruction, connectivity to Microsoft Access, SQL or ODBC databases has never been easier (DataWorx P3K server for PC sold separately). The controller can retrieve, add, delete and update data records in the remote database.

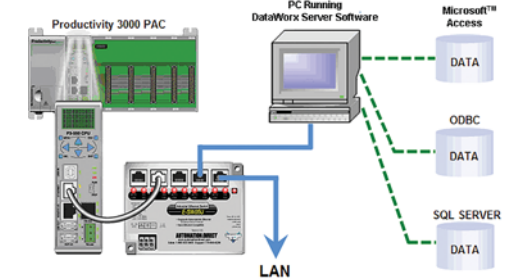

Import tags into C-more database

C-more HMI software has a direct import feature for the Productivity3000 tag database. No duplicating work - bring in all the tag names from the controller program right into C-more's database with just a few keystrokes.