

CATALOGUE

IECEX, ATEX and HazLoc COMPLIANT COMPONENTS

Relay interface modules

Low profile PCB relays

Power relays

Modular timers

Timer modules

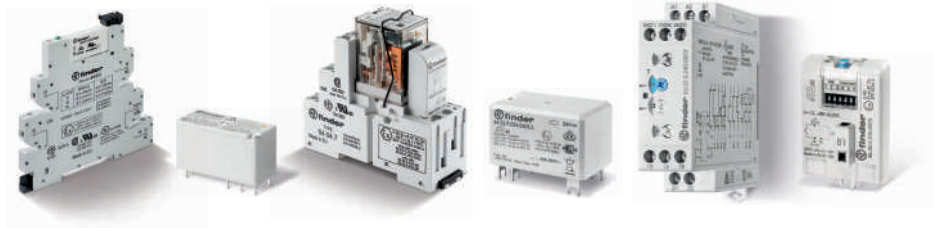

ABOUT US



Finder was founded in Italy in 1954. Since then it has been designing and manufacturing a wide range of electromechanical and electronic components for both the residential and industrial sectors. Today, thanks to its global vision, Finder now distributes its products around the world through a network of 29 company-owned subsidiaries and more than 80 trade partnerships. Finder is an international family made up of more than 2000 individuals, all united by the same values and passion for our products.



14,000+ different products to satisfy a myriad of applications. From products at the heart of automation to the control of machines, power, time, temperature, liquid level and light

OUR PRODUCTS CARRY MORE CERTIFICATIONS THAN ANY OTHER RELAY MANUFACTURER



FINDER IS AN ITALIAN BRAND WITH A WORLDWIDE PRESENCE

- 4** PRODUCTION PLANTS IN EUROPE
- 29** SUBSIDIARIES
- 80+** OFFICIAL DISTRIBUTORS



ENVIRONMENTAL, SOCIAL AND GOVERNANCE (ESG)

Finder considers social and environmental sustainability as fundamental principles of doing business, just as it believes that business growth must develop in synergy with a conscious vision of the future. That is why Finder is committed to reducing and eliminating CO2 emissions, focusing on circularity, caring for its employees to foster a safe, fair and inclusive work environment, spreading a culture of integrity and transparency, and collaborating with stakeholders who share its values.



ISO 9001:2015
Quality management system



IECEx
Equipment for Use in Explosive Atmospheres

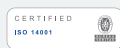

ISO 14001:2015
Environmental management system



ISO 27001-27701
Information Security and Privacy Management System



ISO 45001:2018
Health and safety management system

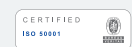

ISO 50001:2018
Energy management system

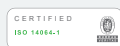

ISO 14064-1:2019
Carbon Footprint verification



AEOF
Simplified customs and enhanced supply chain security



FSC
Forest Stewardship Council



Cribis Prime Company
Recognition of highest reliability of commercial relations

AUTONOMY AND INDEPENDENCE

Finder's managerial, financial and technological autonomy allows optimal control over all its business processes, the results of which include simplified customs procedures and a high reliability of commercial relations.



IECEX, ATEX and HazLoc products are designed for use in environments and applications that can give rise to the risk of explosion if flammable gases are present.

The relevant sectors include: chemical and petrochemical plants, pharmaceuticals, paint and solvent production plants, refrigeration and air conditioning systems.



Features	Rated current	No. of contacts	Page
39 Series - Relay interface modules - ATEX - HazLoc	0.1 A 2 A 6 A	1 CO 1 NO	3
	<ul style="list-style-type: none"> - ATEX compliant: II 3G Ex ec nC IIC Gc - HazLoc Class I Div. 2 Group A, B, C, D - T5 - T6 - Common connection possible with optional jumper links and multipole connector <i>MasterADAPTER</i> Ex nA compliant - UL listing - Timer interface with adjustment via top mounted rotary knob, accessible after assembly - Control signal terminal - DIP-switch for selection of 4 time scales and 8 functions - Electromechanical relay - Solid state relay - AC, AC/DC and Multivoltage extended range Version - Box clamp and Push-in terminal - Cadmium free contacts - Complies with: EN 60079-0: 2012 and EN 60079-15:2010 - 35 mm rail (EN 60715) mounting 		
41 Series - Low profile PCB relays - IECEx - ATEX - HazLoc	8 A 16 A	2 CO 2 NO 1 CO 1 NO	25
	<ul style="list-style-type: none"> - IECEx, ATEX (II 3 G Ex nC IIC Gc) - HazLoc Class I, Zone 2, AEx nC IIC Gc - HazLoc Class I Div. 2, Groups A, B, C, D - T4 - 8 mm, 6 kV (1.2/50 µs) isolation, coil-contacts - DC coils - Cadmium Free contact materials - 15.7 mm height 		
58 Series - Relay interface modules - IECEx - ATEX - HazLoc	6 A 8.5 A 10 A	4 CO 3 CO 2 CO	33
	<ul style="list-style-type: none"> - ATEX IECEx EUT 24.0007 U compliant Ex ec nC IIC Gc - HazLoc Class I Div. 2 Groups A, B, C, D - T5 - Supply status indication and EMC coil suppression module as standard - Timer module optional - Identification label - Cadmium Free contacts - AC coils or DC coils - Mechanical indicator - optional on 2 & 4 CO types - Complies with: EN IEC 60079-0:2018, EN IEC 60079-15:2019 and EN IEC 60079-7:2015 + A1:2018 - 35 mm rail (EN 60715) mounting 		
66 Series - Power relays - ATEX - HazLoc	30 A	2 CO 2 NO	43
	<ul style="list-style-type: none"> - ATEX compliant: II 3 G Ex ec nC IIC Gc - HazLoc Class I Div. 2 Group A, B, C, D - T4 - T5 - T6 - 2 x 30 A DIN Rail and 2 x 25 A PCB mounting relay - ≥ 1.5 mm contact gap version available - Reinforced insulation between coil and contacts according to EN 60335-1; 8 mm creepage and clearance distances - AC coils & DC coils - Cadmium Free option available - Complies with: EN IEC 60079-0:2018, EN IEC 60079-15:2019 and EN IEC 60079-7:2015 + A1:2018 		
83 Series - Modular timers - IECEx - ATEX - HazLoc	10 A	2 CO	53
	<ul style="list-style-type: none"> - IECEx ULD 23.0013 X - E497395 - IECEx, ATEX compliant: Ex ec nC IIC T4 Gc - HazLoc Class I Div. 2 Group A, B, C, D - T4 - HazLoc Class I, Zone 2, AEx ec nC IIC T4 Gc - Eight time scales from 0.05 s to 10 days - High input/output isolation - Wide supply range (24...240)V AC/DC - "Blade + cross" - both flat blade and cross head screw drivers can be used to adjust the range and function selectors, the timing trimmer, and to disengage the rail mounting clip - Multi-voltage versions with "PWM clever" technology - 22.5 mm wide - 35 mm rail (EN 60715) mounting 		

Features

Rated current **No. of contacts** **Page**



86 Series - Timer modules - ATEX - HazLoc

- ATEX compliant: II 3G Ex ec IIC Gc
- HazLoc Class I Div. 2 Group A, B, C, D - T6
- Timer module type 86.00 for 90, 92, 96 series sockets and type 86.30 for 90, 92, 94, 95, 96, 97 series sockets
- Wide supply voltage range:
12...48 V AC/DC (86.00)
12...24 V AC/DC (86.30)
- LED indicator
- Complies with: EN 60079-0:2012+A11:2013, EN 60079-15:2010, EN 60079-7:2015

—

—

61

Relay interface modules 0.1 - 2 - 6 A - ATEX - HazLoc



Common features

- Space saving 6.2 mm wide
- Connections for 16-way jumper link
- Integral coil indication and protection circuit
- Secure retention and easy ejection by plastic clip
- Dual screw head (blade+cross) terminals and Push-in terminals versions
- 35 mm rail mounting (EN 60715)

EMR
Electromechanical Relays

- **1 CO 6 A/250 V AC**
- High switching capability

SSR
Solid State Relays

- 1 solid state output (options **0.1 A/48 V DC**, **6 A/24 V DC**, **2 A/240 V AC**)
- Silent, high speed switching, long electrical life

MasterBASIC

- For general use in any type of system
- **EMR: 6 to 24 and 125 V AC/DC, 230 V AC supply**
- **SSR: 6 to 24 and 125 V AC/DC, 230 V AC supply**
- **Multi-voltage EMR or SSR, 24...240 V AC/DC supply**
- Box clamp and Push-in terminal

39.11/39.01



Page 5

39.10/39.00



Page 6

MasterTIMER

- Timer adjustment via top mounted rotary knob accessible after assembly
- Control signal terminal
- DIP-switch for selection of 4 time scales and 8 functions
- **EMR and SSR: 12 to 24 V AC/DC supply**
- Box clamp and Push-in terminal

39.81/39.91

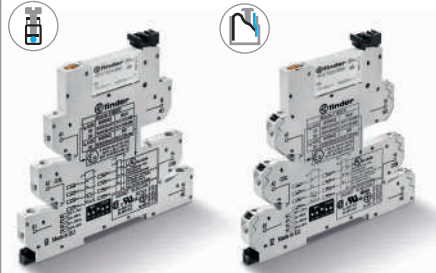

Page 7

39.80/39.90

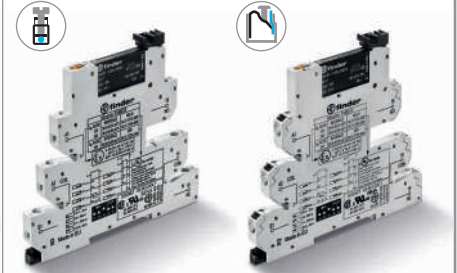

Page 8

MasterBASIC

39.11 - 39.10 - 39.01 - 39.00

- For general interface use in any type of system and application.
- Can be used for input interface applications between auxiliary contacts, sensors etc. and controllers, PLC's or motors. Or for output interface between PLC's controllers and relays, solenoids etc.

MasterTIMER

39.81 - 39.80 - 39.91 - 39.90

- Slim and Multifunction Timed Interface modules.

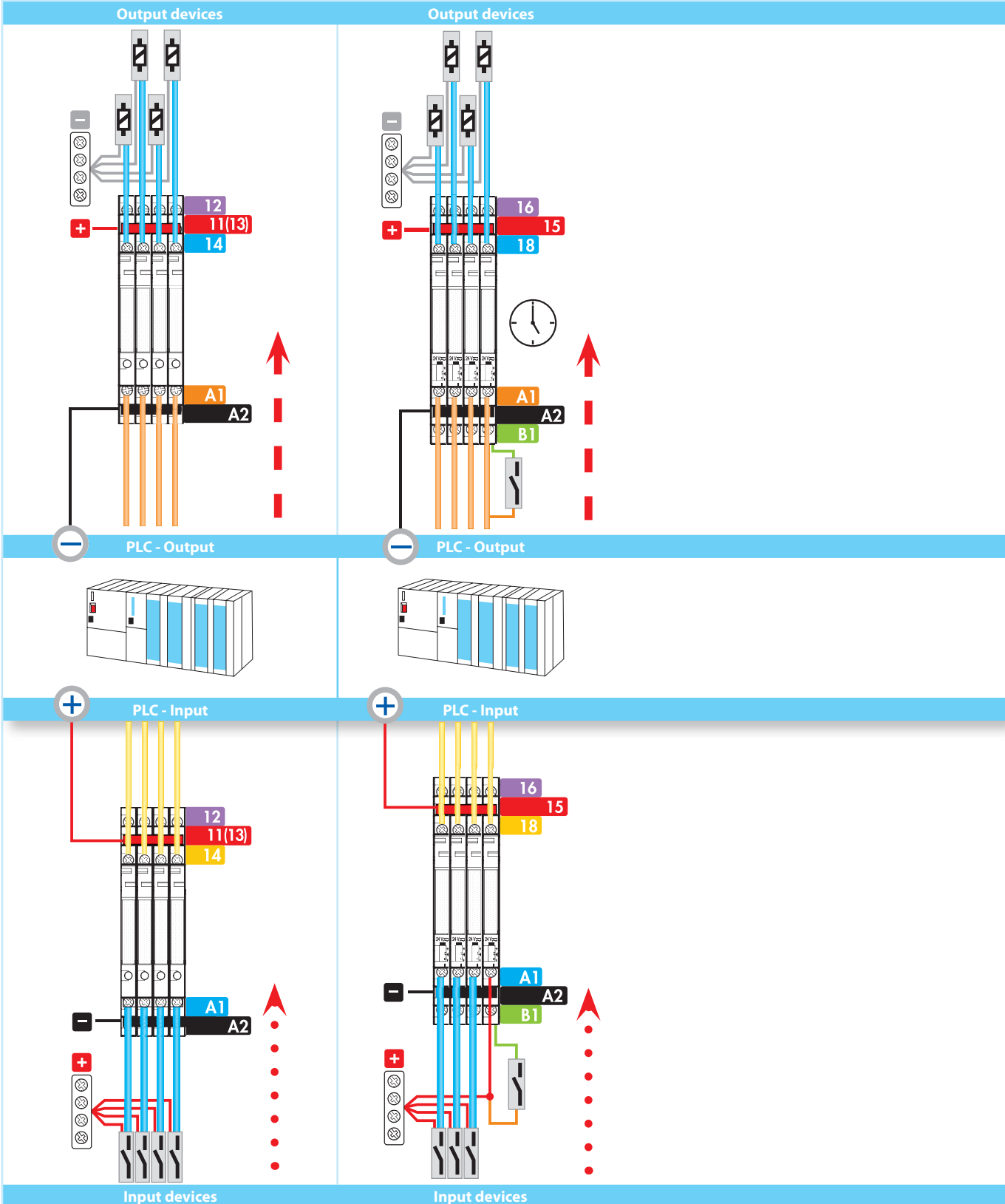

MasterBASIC - EMR ATEX

1 Pole interface module, 6.2 mm wide, ideal for PLC and electronic systems

ATEX compliant (Ex ec nC)

HazLoc Class I Div. 2 Group A, B, C, D - T6

- Electromechanical relay
- AC and AC/DC Version
- Box clamp and Push-in terminal
- UL Listed
- Cadmium free contacts
- Complies with:
 - EN 60079-0: 2012 and EN 60079-15:2010
- Common connection possible with optional jumper links (terminals A1, A2 and 11) and multipole connector **MasterADAPTER**
- 35 mm rail (EN 60715) mounting

39.11/39.01



- 1 CO 6 A
- Box clamp and push-in terminal
- 35 mm rail (EN 60715) mounting
- ATEX compliant

39.11
Box clamp



39.01
Push-in terminal

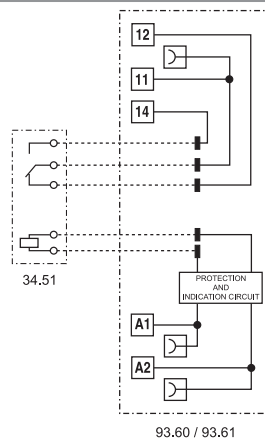

For outline drawing see page 18

Contact specification

Contact configuration		1 CO (SPDT)
Rated current/ Maximum peak current	A	6/10
Rated voltage/ Maximum switching voltage	V AC	250/400
Rated load AC1	VA	1500
Rated load AC15 (230 V AC)	VA	300
Single phase motor rating (230 V AC)	kW	0.185
Breaking capacity DC1: 24/110/220 V	A	6/0.2/0.12
Minimum switching load	mW (V/mA)	500 (12/10)
Standard contact material		AgNi

Coil specification

Nominal voltage (U _N)	V AC/DC	6 - 12 - 24 - 110...125 - 24...240
	V AC (50/60 Hz)	230...240
Rated power AC/DC	VA (50 Hz)/W	See page 13
Operating range		(0.8...1.1)U _N
Holding voltage		0.6 U _N
Must drop-out voltage		0.1 U _N

Technical data

Mechanical life AC/DC	cycles	10 · 10 ⁶
Electrical life at rated load AC1	cycles	60 · 10 ³
Operate/release time	ms	5/6
Insulation between coil and contacts (1.2/50 μs)	kV	6 (8 mm)
Dielectric strength between open contacts	V AC	1000
Ambient temperature range	°C	-40...+70
Protection category		IP 20

Approvals relay (according to type)



MasterTIMER - EMR - Ex

Slim timed interface module, 6.2 mm wide, ideal for space-saving timing solutions in panels

- Timer adjustment via top mounted rotary knob, accessible after assembly
- Control signal terminal
- DIP-switch for selection of 4 time scales and 8 functions
- Common connection possible with optional jumper links (terminals A1, A2 and 15)
- **ATEX** compliant (Ex ec nC)
- **HazLoc** Class I Div. 2 Group A, B, C, D - T6

39.81/39.91

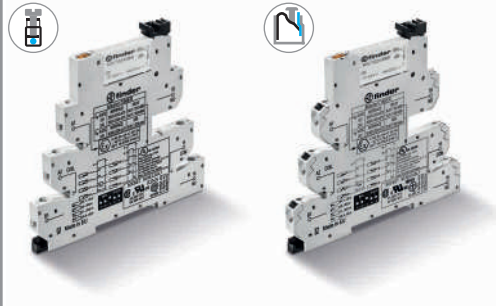

- 6 A electromechanical relay
- 12 - 24 V AC/DC supply
- Box clamp and push-in terminal
- 35 mm rail (EN 60715) mounting

39.81
Box clamp



39.91
Push-in terminal



* See L39 derating diagram at page 12

For outline drawing see page 18

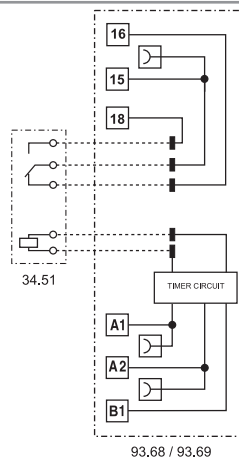

- AI:** On-delay
- DI:** Interval
- GI:** Pulse (0.5 s) delayed
- SW:** Symmetrical flasher (starting pulse on)
- BE:** Off-delay with control signal
- CE:** On- and off-delay with control signal
- DE:** Interval with control signal on
- EE:** Interval with control signal off

Contact specification		
Contact configuration		1 CO (SPDT)
Rated current/ Maximum peak current	A	6/10
Rated voltage/ Maximum switching voltage	V AC	250/400
Rated load AC1	VA	1500
Rated load AC15 (230 V AC)	VA	300
Single phase motor rating (230 V AC)	kW	0.185
Breaking capacity DC1: 24/110/220 V	A	6/0.2/0.12
Minimum switching load	mW (V/mA)	500 (12/10)
Standard contact material		AgNi
Supply specification		
Nominal voltage (U _N)	V AC/DC	12 - 24
Rated power AC/DC	VA (50 Hz)/W	See page 13
Operating range		(0.8...1.1)U _N
Holding voltage		0.6 U _N
Must drop-out voltage		0.1 U _N
Technical data		
Specified time range		(0.1...3)s, (3...60)s, (1...20)min, (0.3...6)h
Repeatability	%	± 1
Recovery time	ms	≤ 50
Minimum control impulse	ms	50
Setting accuracy - full range	%	5
Electrical life at rated load AC1	cycles	60 · 10 ³
Ambient temperature range*	°C	-20...+50
Protection category		IP 20
Approvals relay (according to type)		

MasterBASIC - SSR - HazLoc

1 Pole interface module, 6.2 mm wide, ideal for PLC and electronic systems

- Common connection possible with optional jumper links (terminals A1, A2 and 13+)
- HazLoc Class I Div. 2 Group A, B, C, D - T5 - T6

39.10/39.00

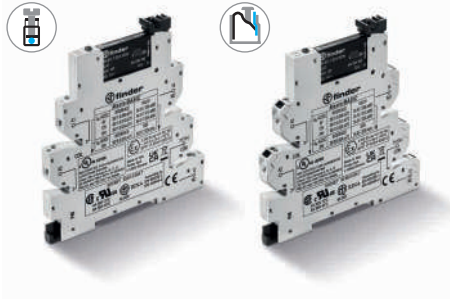

- 0.1, 2 or 6 A solid state relay
- 6 to 24 and 125 V AC/DC and 230 V AC supply
- Box clamp and push-in terminal
- 35 mm rail (EN 60715) mounting

39.10
Box clamp



39.00
Push-in terminal

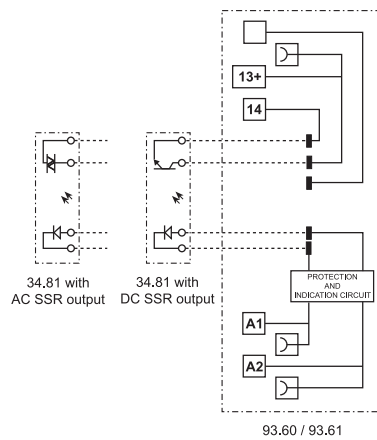

* See L39-1 and L39-2 derating diagram at page 14

For outline drawing see page 18

Output specification (SSR)		39.x0.x.xxx.9073	39.x0.x.xxx.7073	39.x0.x.xxx.8273
Contact configuration		1 NO (SPST-NO)		
Rated current/ Maximum peak current (10 ms)	A	6/50	0.1/0.5	2/80
Rated voltage/ Maximum blocking voltage	V	24/33 DC	48/53 DC	240/— AC
Switching voltage range	V	(1.5...33) DC	(1.5...53) DC	(12...275) AC
Repetitive peak off-state voltage	V _{pk}	—	—	800
Minimum switching current	mA	1	0.05	35
Max. "OFF-state" leakage current	mA	0.001	0.001	1.5
Max. "ON-state" voltage drop	V	0.4	1	1.6
Supply specification				
Nominal voltage (U _N)	V AC/DC	110...125		
	V AC (50/60 Hz)	220...240		
	V AC/DC	6 - 12 - 24		
Rated power	VA (50 Hz)/W	See page 15		
Operating range		(0.8...1.1)U _N		
Must drop-out voltage		0.1 U _N		
Technical data				
Operate/release time	ms	0.2/0.6	0.04/0.6	12/12
Dielectric strength between input/output	V AC	3000		
Ambient temperature range*	°C	-20...+70		
Protection category		IP 20		
Approvals relay (according to type)				

MasterTIMER - SSR - Hazloc

Slim timed interface module, 6.2 mm wide, ideal for space-saving timing solutions in panels

- Timer adjustment via top mounted rotary knob; accessible after assembly
- Control signal terminal
- DIP-switch for selection of 4 time scales and 8 functions
- Common connection possible with optional jumper links (terminals A1, A2 and 15+)
- **HazLoc** Class I Div. 2 Group A, B, C, D - T5 - T6

39.80/39.90

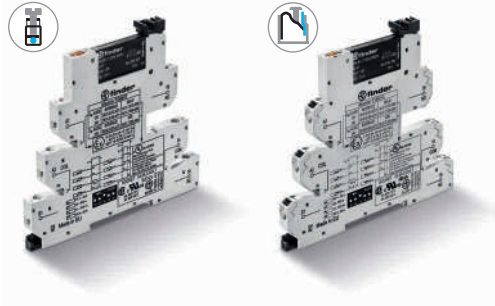

- 0.1, 2 or 6 A solid state relay
- 12 - 24 V AC/DC supply
- Box clamp and push-in terminal
- 35 mm rail (EN 60715) mounting

39.80
Box clamp



39.90
Push-in terminal

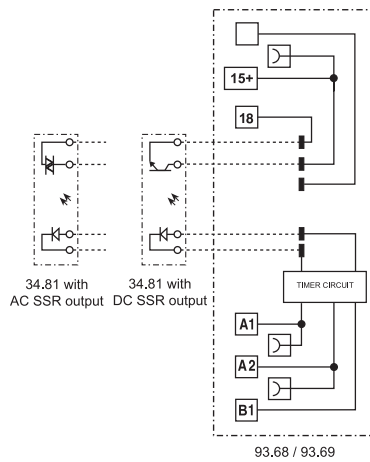

- AI:** On-delay
- DI:** Interval
- GI:** Pulse (0.5 s) delayed
- SW:** Symmetrical flasher (starting pulse on)
- BE:** Off-delay with control signal
- CE:** On- and off-delay with control signal
- DE:** Interval with control signal on
- EE:** Interval with control signal off

* See L39-1 and L39-2 derating diagram at page 14

For outline drawing see page 18

Output specification (SSR)		39.x0.x.xxx.9073	39.x0.x.xxx.7073	39.x0.x.xxx.8273
Contact configuration		1 NO (SPST-NO)		
Rated current/ Maximum peak current (10 ms)	A	6/50	0.1/0.5	2/80
Rated voltage/ Maximum blocking voltage	V	24/33 DC	48/53 DC	240/— AC
Switching voltage range	V	(1.5...33) DC	(1.5...53) DC	(12...275) AC
Repetitive peak off-state voltage	V _{pk}	—	—	800
Minimum switching current	mA	1	0.05	35
Max. "OFF-state" leakage current	mA	0.001	0.001	1.5
Max. "ON-state" voltage drop	V	0.4	1	1.6
Supply specification				
Nominal voltage (U _N)	V AC/DC	12 - 24		
Rated power	VA (50 Hz)/W	See page 15		
Operating range		(0.8...1.1)U _N		
Holding voltage		0.6 U _N		
Must drop-out voltage		0.1 U _N		
Technical data				
Specified time range		(0.1...3)s, (3...60)s, (1...20)min, (0.3...6)h		
Repeatability	%	± 1		
Recovery time	ms	≤ 50		
Minimum control impulse	ms	50		
Setting accuracy – full range	%	5		
Ambient temperature range*	°C	-20...+50		
Protection category		IP 20		
Approvals relay (according to type)				

Technical data

Insulation according to EN 61810-1			
Nominal voltage of supply system	V AC	230/400	
Rated insulation voltage	V AC	250	400
Pollution degree		3	2
Insulation between coil and contact set			
Type of Insulation		Reinforced	
Overvoltage category		III	
Rated impulse voltage	kV (1.2/50) μ s	6	
Dielectric strength	V AC	4000	
Insulation between open contacts (EMR)			
Type of disconnection		Micro-disconnection	
Dielectric strength	V AC/kV (1.2/50) μ s	1000/1.5	

Conducted disturbance immunity		$U_N \leq 60$ V	$U_N = 125$ V	$U_N = 230$ V
Fast transients (burst 5/50 ns, 5 kHz) according to EN 61000-4-4 at supply terminals	kV	4	4	4
Voltage pulses (surge 1.2/50 μ s) according to EN 61000-4-5 at supply terminals (differential mode)	kV	0.8	2	4

Other data			
Bounce time (EMR): NO/NC	ms	1/6	
Vibration resistance (EMR, 10...55 Hz): NO/NC	g	10/15	
Power lost to the environment	without contact current	W	0.2 (24 V) - 0.4 (230 V)
	with rated current	W	0.6 (24 V) - 0.9 (230 V)

Terminals			
		Box clamp	Push-in terminal
Wire strip length	mm	10	8
 Screw torque	Nm	0.5	—
		Solid and stranded cable	Solid and stranded cable
Min. wire size	mm ²	1 x 0.5	1 x 0.5
	AWG	1 x 21	1 x 21
Max. wire size	mm ²	1 x 2.5	1 x 2.5
	AWG	1 x 14	1 x 14

Ordering information ATEX - HazLoc versions

Example: 39 series, box clamp interface module, electromechanical relay output, 1 CO 6 A, 24 V AC/DC, ATEX - HazLoc version.

<p>Series ————</p> <p>Type ————</p> <p>0 = Push-in terminals 35 mm rail (EN 60715) mounting</p> <p>1 = Box clamp 35 mm rail (EN 60715) mounting</p> <p>8 = TIMER multifunction, box clamp</p> <p>9 = TIMER multifunction, push-in terminal</p> <p>No. of poles ————</p> <p>0 = 1 NO (only SSR)</p> <p>1 = 1 CO, 6 A</p> <p>Coil version ————</p> <p>0 = AC/DC</p> <p>8 = AC (50/60 Hz)</p> <p>Coil voltage ————</p> <p>See coil specifications</p>	<p>A B C D</p> <p>3 9 . 1 1 . 0 . 0 2 4 . 0 0 7 3</p>	<p>A - B: Contact material - circuit</p> <p>00 = EMR AgNi contact CO (nPDT) Up to 6 A 250 V AC ATEX and Hazloc compliant</p> <p>50 = EMR AgNi + Au contact CO (nPDT) Up to 6 A 250 V AC ATEX and Hazloc compliant</p> <p>70 = SSR NO (SPST-NO) Up to 0.1 A - 48 V DC HazLoc compliant</p> <p>82 = SSR NO (SPST-NO) Up to 0.75 A - 277 V AC HazLoc compliant</p> <p>90 = SSR NO (SPST-NO) Up to 5 A - 24 V DC HazLoc compliant</p>	<p>C - D: Option</p> <p>73 = ATEX (Ex ec nC) and HazLoc Class I Div. 2 interface with EMR relay, or HazLoc Class I Div. 2 interface with SSR relay</p>
---	---	--	---

ATEX - Electrical characteristics

Max current @ 70 °C	Single piece mount	> 8 piece mount
Type 39.11/01	A 6	5
Type 39.11/01 (110...125)V AC/DC only	A 6	4
Terminals	Box clamp	Push-in Terminals
Wire strip length	mm 10	8
Screw torque	Nm 0.5	—
Min. wire size	solid and stranded cable	solid and stranded cable
	mm ² 0.5	0.5
	AWG 21	21
Max. wire size	solid and stranded cable	solid and stranded cable
	mm ² 1 x 2.5	1 x 2.5
	AWG 1 x 14	1 x 14

Markings - ATEX versions - ATEX, II 3G Ex ec nC IIC Gc

MARKING	
	Specific marking of explosion protection
II	Component for surface plant (different from mines)
3	Category 3: normal level of protection
GAS	G Explosive atmosphere due to presence of combustible gas vapour or mist
	Ex ec Increased safety
	Ex nC Sealed device (type of protection for category 3G)
	IIC Gas group
	Gc Equipment Protection Level
-40 °C ≤ Ta ≤ +70 °C Ambient temperature	
EPTI 17 ATEX 0303 U EPTI: laboratory which issues the CE type certificate 17: year of issue of certificate 0303: number of CE type certificate U: ATEX component	

Markings - Hazardous Location Class I Div. 2 Groups A, B, C, D - T5 - T6 and other data

HazLoc Class I Div. 2 Group A, B, C, D - T5 - T6		Meaning
Class I		Areas in which flammable gases and vapours may be present
Div. 2		Low probability to find ignitable concentration of hazards because are typically present in containers or closed systems from which can escape through their accidental rupture or breakdown
Group A, B, C, D		Kind of combustible, flammable gases and vapours can be in the atmosphere
Permissible Surface temperature		
T5	100 °C	212 °F
T6	85 °C	185 °F

Interface Code	Temperature code @ 40°C	40 °C		Temperature code @ 70 °C	70 °C	
		Current	Voltage		Current	Voltage
39.11.0.024.0073	T6	6 A (NO)	250 V AC	—	—	—
39.10.0.024.8273	T5	0.75 A	277 V AC	—	—	—
39.10.0.024.9073	T6	5 A	24 V DC	T5	4 A	24 V DC
39.11.8.230.0073	T6	6 A (NO)	250 V AC	—	—	—
39.10.8.230.8273	T5	0.75 A	277 V AC	—	—	—
39.10.8.230.9073	T6	5 A	24 V DC	T5	4 A	24 V DC
39.01.0.240.0073	T6	6 A (NO)	250 V AC	—	—	—
39.00.0.240.8273	T5	0.75 A	277 V AC	—	—	—
39.00.0.240.9073	T6	5 A	24 V DC	T5	4 A	24 V DC
39.91.0.024.0073	T6	6 A (NO)	250 V AC	—	—	—
39.90.0.024.8273	T5	0.75 A	277 V AC	—	—	—
39.90.0.024.9073	T6	5 A	24 V DC	T5	4 A	24 V DC

Contact specification- Electromechanical Relay

F 39 - Electrical life (AC) v contact current

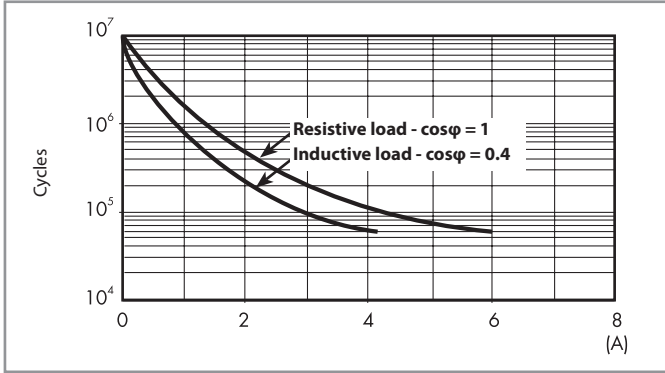

H 39 - Maximum DC1 breaking capacity

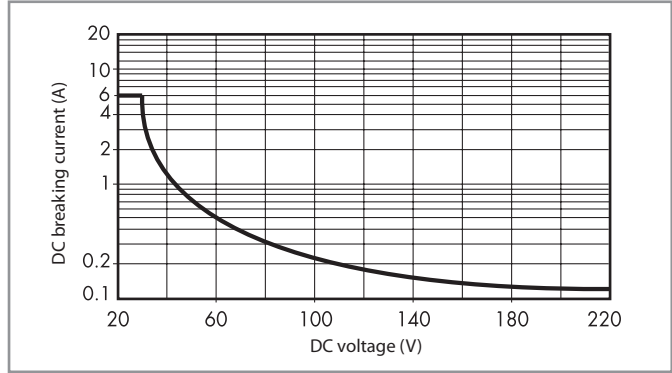

- When switching a resistive load (DC1) having voltage and current values under the curve, an electrical life of $\geq 60 \cdot 10^3$ can be expected.
- In the case of DC13 loads, the connection of a diode in parallel with the load will permit a similar electrical life as for a DC1 load.
Note: the release time for the load will be increased.

L 39 - Output current v ambient temperature

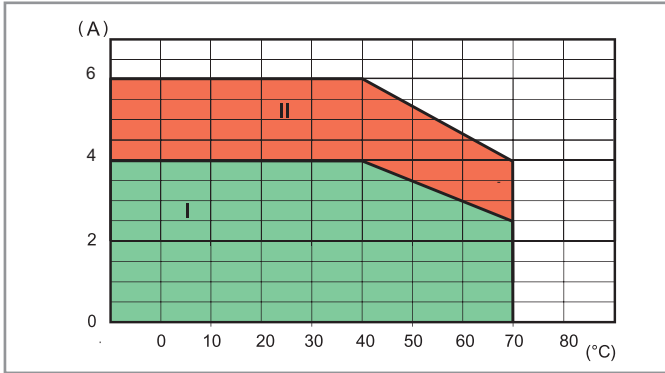

- I:** 39 series installed as a group (without gap between sockets) with fuse module inserted
- II:** 39 series installed as a group with "bridging" module, or individually with fuse module

Coil specifications - Electromechanical Relay

Coil data AC/DC - Types 39.11/01

Nominal voltage U_N	Coil code	Operating range		Must drop-out voltage U_r	Rated input current at U_N I_N	Rated power at U_N
		U_{min}	U_{max}			
V		V	V	V	mA	VA/W
6	0.006	4.8	6.6	0.6	35	0.2/0.2
12	0.012	9.6	13.2	1.5	15	0.2/0.2
24	0.024	19.2	26.4	2.4	11	0.25/0.25
125 (110...125)	0.125	88	138	12.5	5.6	0.7/0.7
240 (24...240)	0.240	20.4	264	2.4	19	1.5/0.3

Coil data AC - Types 39.11/01

Nominal voltage U_N	Coil code	Operating range		Must drop-out voltage U_r	Rated input current at U_N I_N	Rated power at U_N
		U_{min}	U_{max}			
V		V	V	V	mA	VA/W
230 (230...240)	8.230	184	264	23	4.3	1/0.4

Coil data AC/DC timer - Types 39.81/91

Nominal voltage U_N	Coil code	Operating range (AC/DC)		Must drop-out voltage U_r	Rated input current at U_N		Rated power at U_N	
		U_{min}	U_{max}		DC mA	AC mA	DC W	AC VA/W
V		V	V	V	mA	mA	W	VA/W
12	0.012	9.6	13.2	1.2	15	23	0.2	0.3/0.2
24	0.024	19.2	26.4	2.4	11	19	0.25	0.4/0.3

Output specification - Solid State Relays

L 39-1 - Output DC current v ambient temperature

39.x0.x.xxx.9073

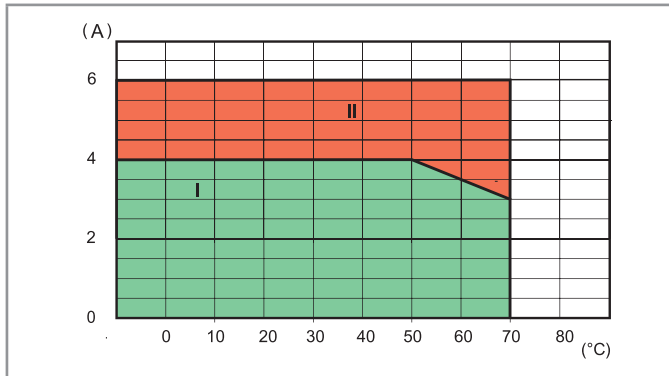

L 39-2 - Output AC current v ambient temperature

39.x0.x.xxx.8273

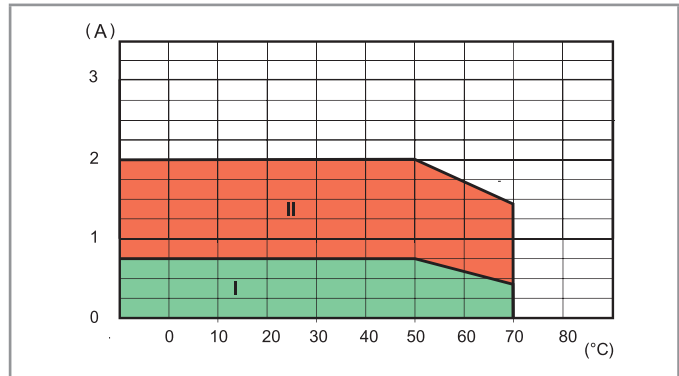

I: SSR installed as a group (without gap between sockets)

II: SSR installed individually in free air, or with a gap ≥ 9 mm, which implies a not significant influence from nearby components

Max recommended switching frequency (Cycles/Hour, with 50% Duty-cycle) at ambient temperature 50°C, single mounting

Load	39.x0.x.xxx.9073	39.x0.x.xxx.8273	39.x0.x.xxx.7073
24 V 6 A DC1	180 000	—	—
24 V 3 A DC L/R = 10 ms	5000	—	—
24 V 2 A DC L/R = 40 ms	3600	—	—
24 V 1 A DC L/R = 40 ms	6500	—	—
24 V 0.8 A DC L/R = 40 ms	9000	—	—
24 V 1.5 A DC L/R = 80 ms	3250	—	—
230 V 2 A AC1	—	60 000	—
230 V 1.25 A AC15	—	3600	—
48 V 0.1 A DC1	—	—	60 000

Input specifications - Solid State Relay

Input data AC/DC - Types 39.10/00

Nominal voltage U_N	Input code	Operating range		Must drop-out voltage U_r	Rated input current at U_N		Rated power at U_N
		U_{min}	U_{max}		I_N		
V		V	V	V	mA		VA/W
6	0.006	4.8	6.6	0.6	35		0.2/0.2
12	0.012	9.6	13.2	1.5	15		0.2/0.2
24	0.024	19.2	26.4	2.4	17.5		0.4/0.3
125 (110...125)	0.125	88	138	12.5	5.5		0.7/0.7
240 (24...240)	0.240	20.4	264	2.4	17.5		1.5/0.3

Input data AC - Types 39.10/00

Nominal voltage U_N	Input code	Operating range		Must drop-out voltage U_r	Rated input current at U_N		Rated power at U_N
		U_{min}	U_{max}		I_N		
V		V	V	V	mA		VA/W
230 (230...240)	8.230	184	264	23	4.2		1/0.4

Input data AC/DC timer - Types 39.80/90

Nominal voltage U_N	Input code	Operating range (AC/DC)		Must drop-out voltage U_r	Rated input current at U_N		Rated power at U_N	
		U_{min}	U_{max}		DC	AC	DC	AC
V		V	V	V	mA	mA	W	VA/W
12	0.012	9.6	13.2	1.2	15	23	0.2	0.3/0.2
24	0.024	19.2	26.4	2.4	11	19	0.25	0.4/0.3

Timer specifications

EMC specifications

Type of test		Reference standard	
Electrostatic discharge	contact discharge	EN 61000-4-2	4 kV
	air discharge	EN 61000-4-2	8 kV
Radio-frequency electromagnetic field	(80 ÷ 1000 MHz)	EN 61000-4-3	10 V/m
	(1400 ÷ 2700 MHz)	EN 61000-4-3	10 V/m
Fast transients (burst) (5-50 ns, 5 and 100 kHz)	on Supply terminals	EN 61000-4-4	4 kV
	on control signal terminals	EN 61000-4-4	4 kV
Surges (1.2/50 µs) on supply and control signal terminals	common mode	EN 61000-4-5	2 kV
	differential mode	EN 61000-4-5	0.8 kV
Radio-frequency common mode (0.15 ÷ 80 MHz)	on Supply terminals	EN 61000-4-6	10 V
	on control signal terminals	EN 61000-4-6	3 V
Radiated and conducted emission		EN 55022	class B

Other data

Bounce time (EMR): NO/NC	ms	1/6	
Vibration resistance (EMR, 10...55 Hz): NO/NC	g	10/15	
Power lost to the environment	without contact current	W	0.3
	with rated current	W	0.8

Terminals

		Box clamp	Push-in terminal
Wire strip length	mm	10	8
Screw torque	Nm	0.5	—
		Solid and stranded cable	Solid and stranded cable
Min. wire size	mm ²	1 x 0.5	1 x 0.5
	AWG	1 x 21	1 x 21
Max. wire size	mm ²	1 x 2.5	1 x 2.5
	AWG	1 x 14	1 x 14

Times scales



Functions

LED	Supply voltage	NO contact/output
	OFF	Open
	ON	Open
	ON	Open (timing to close in progress)
	ON	Closed

Wiring diagram

U = Supply voltage

S = Signal switch

= Output contact

Without control signal

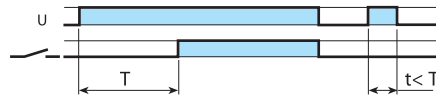
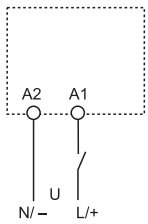

(AI) On-delay

Apply power to timer. Output contacts transfer after preset time has elapsed. Reset occurs when power is removed.

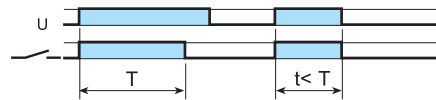

(DI) Interval

Apply power to timer. Output contacts transfer immediately. After the preset time has elapsed, contacts reset.

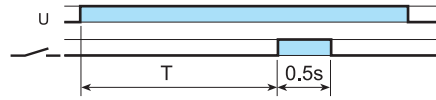

(GI) Pulse (0.5 s) delayed

Apply power to timer. Output contacts transfer after preset time has elapsed. Reset occurs after a fixed time of 0.5 s.

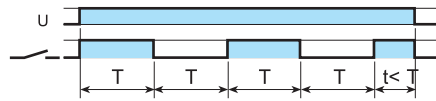

(SW) Symmetrical flasher (starting pulse on)

Apply power to timer. Output contacts transfer immediately and cycle between ON and OFF for as long as power is applied. The ratio is 1:1 (time on = time off).

With control signal

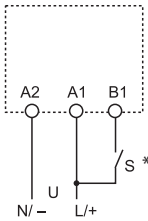

* With DC supply, positive polarity has to be connected to B1, terminal (according to EN 60204-1).

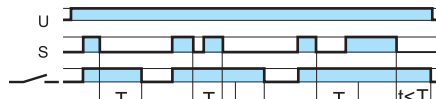

(BE) Off-delay with control signal

Power is permanently applied to the timer. The output contacts transfer immediately on closure of the Signal Switch (S). Opening the Signal Switch initiates the preset delay, after which time the output contacts reset.

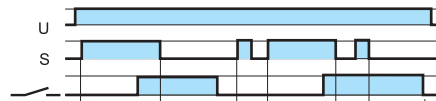

(CE) On- and off-delay with control signal

Power is permanently applied to the timer. Closing the Signal Switch (S) initiates the preset delay, after which time the output contacts transfer. Opening the Signal switch initiates the same preset delay, after which time the output contacts reset.

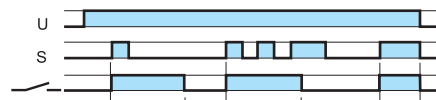

(DE) Interval with control signal on

Power is permanently applied to the timer. On momentary or maintained closure of Signal Switch (S), the output contacts transfer, and remain so for the duration of the preset delay, after which they reset.

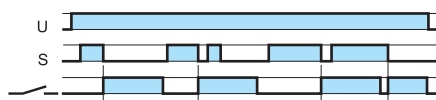

(EE) Interval with control signal off

Power is permanently applied to the timer. On opening of the Signal Switch (S) the output contacts transfer, and remain so for the duration of the preset delay, after which they reset.

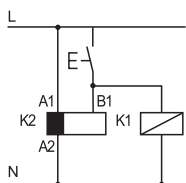

• Possible to control an external load, such as another relay coil or timer, connected to the control signal terminal B1.

** A voltage other than the supply voltage can be applied to the command Start (B1), example:
A1 - A2 = 24 V AC
B1 - A2 = 12 V DC

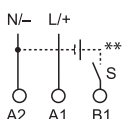

Outline drawings - Box clamp sockets

Types 39.10/39.11
Box clamp

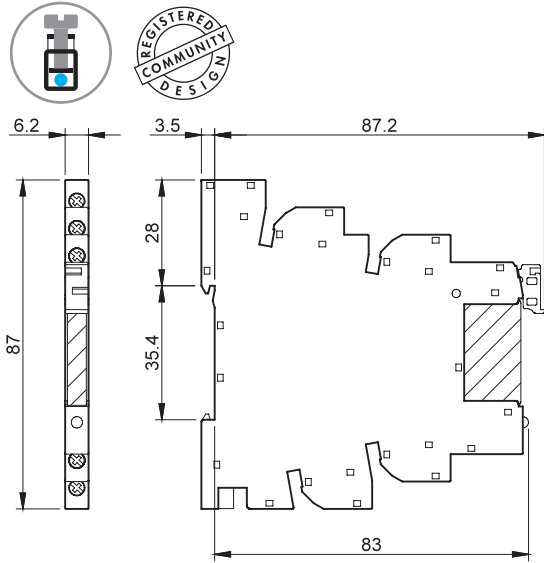

Types 39.80/39.81
Box clamp

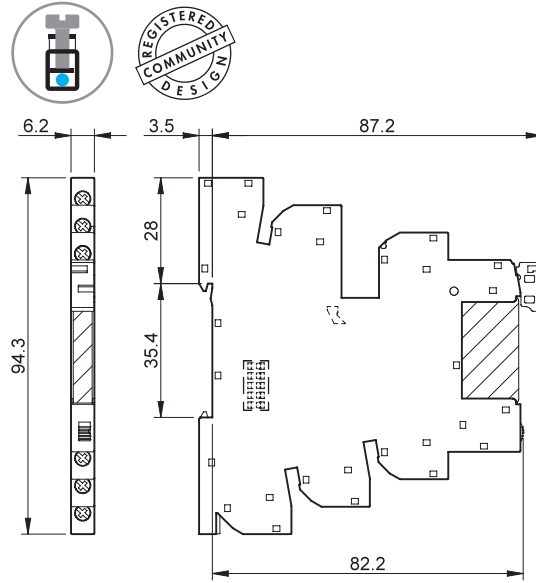

Outline drawings - Push-in terminal sockets

Types 39.00/39.01
Push-in terminal

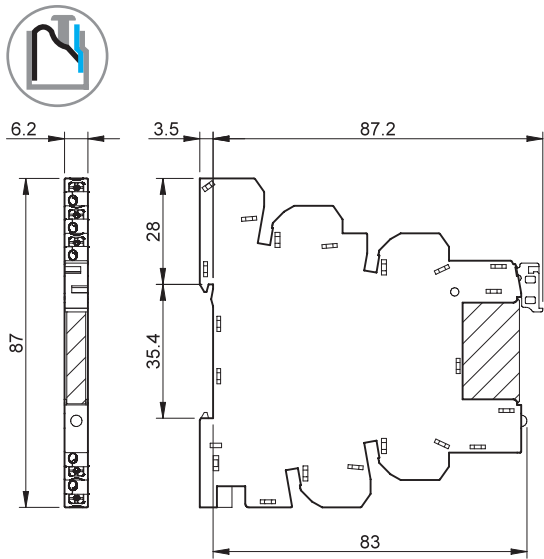

Types 39.90/39.91
Push-in terminal

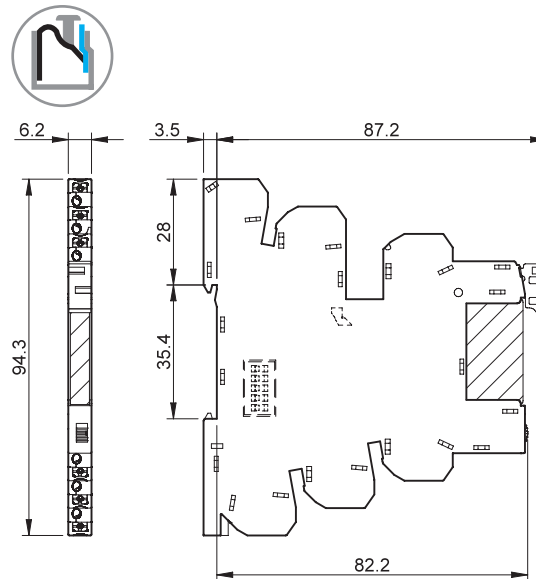

Main features

Push-in terminals

The push-in terminals permit the quick connection of solid wires or ferrules by their simple insertion into the terminal (A). It is possible to open the terminal to extract the wire by first pushing down on the push-button using a screwdriver (C). For stranded cable it is necessary first to open the terminal using the push button, both for the extraction (C) and insertion (B). It is possible at any time to check the connection via the test aperture, using a 2 mm diameter test probe (D).

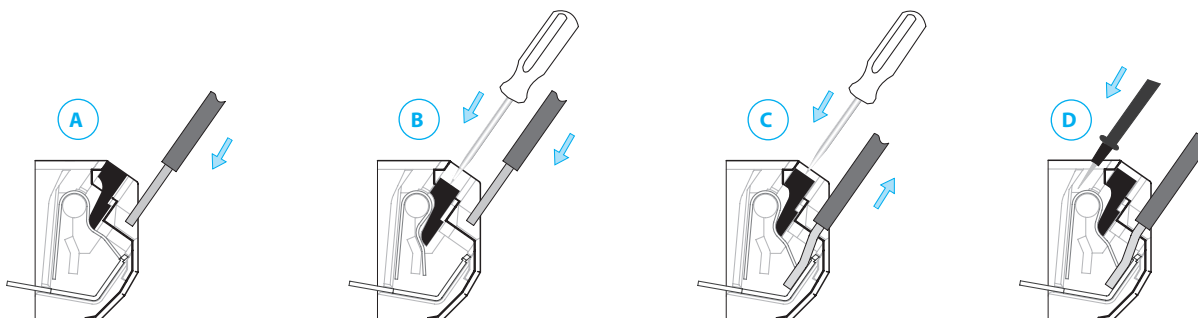

MasterBASIC ATEX/HazLoc - EMR version, Screw Socket Combinations

Interface Module Code	Coil voltage	Relay	Socket
<i>MasterBASIC ATEX</i>			
39.11.0.006.0073	6 V AC/DC	34.51.7.005.0000	93.61.0.024.7
39.11.0.012.0073	12 V AC/DC	34.51.7.012.0000	93.61.0.024.7
39.11.0.024.0073	24 V AC/DC	34.51.7.024.0000	93.61.0.024.7
39.11.0.125.0073	(110...125)V AC/DC	34.51.7.060.0000	93.61.0.125.7
39.11.0.240.0073	(24...240)V AC/DC	34.51.7.024.0000	93.61.0.240.7
39.11.8.230.0073	(230...240)V AC	34.51.7.060.0000	93.61.8.230.7

MasterBASIC ATEX/HazLoc - EMR version, Push-in Socket Combinations

Interface Module Code	Input voltage	Relay	Socket
<i>MasterBASIC ATEX</i>			
39.01.0.006.0073	6 V AC/DC	34.51.7.005.0000	93.60.0.024.7
39.01.0.012.0073	12 V AC/DC	34.51.7.012.0000	93.60.0.024.7
39.01.0.024.0073	24 V AC/DC	34.51.7.024.0000	93.60.0.024.7
39.01.0.125.0073	(110...125)V AC/DC	34.51.7.060.0000	93.60.0.125.7
39.01.0.240.0073	(24...240)V AC/DC	34.51.7.024.0000	93.60.0.240.7
39.01.8.230.0073	(230...240)V AC	34.51.7.060.0000	93.60.8.230.7

MasterTIMER ATEX/HazLoc - EMR version, Screw Socket Combinations

Interface Module Code	Input voltage	Relay	Socket
<i>MasterTIMER ATEX</i>			
39.81.0.012.0073	12 V AC/DC	34.51.7.012.0000	93.68.0.024.7
39.81.0.024.0073	24 V AC/DC	34.51.7.024.0000	93.68.0.024.7

MasterTIMER ATEX/HazLoc - EMR version, Push-in Socket Combinations

Interface Module Code	Input voltage	Relay	Socket
<i>MasterTIMER ATEX</i>			
39.91.0.012.0073	12 V AC/DC	34.51.7.012.0000	93.69.0.024.7
39.91.0.024.0073	24 V AC/DC	34.51.7.024.0000	93.69.0.024.7

MasterBASIC HazLoc - SSR version, Screw Socket Combinations

Interface Module Code	Input voltage	Relay	Socket
<i>MasterBASIC HazLoc</i>			
39.10.0.006.yy73	6 V AC/DC	34.81.7.005.xxxx	93.61.0.024.7
39.10.0.012.yy73	12 V AC/DC	34.81.7.012.xxxx	93.61.0.024.7
39.10.0.024.yy73	24 V AC/DC	34.81.7.024.xxxx	93.61.0.024.7
39.10.0.125.yy73	(110...125)V AC/DC	34.81.7.060.xxxx	93.61.0.125.7
39.10.0.240.yy73	(24...240)V AC/DC	34.81.7.024.xxxx	93.61.0.240.7
39.10.8.230.yy73	(230...240)V AC	34.81.7.060.xxxx	93.61.8.230.7

MasterBASIC HazLoc - SSR version, Push-in Socket Combinations

Interface Module Code	Input voltage	Relay	Socket
<i>MasterBASIC HazLoc</i>			
39.00.0.006.yy73	6 V AC/DC	34.81.7.005.xxxx	93.60.0.024.7
39.00.0.012.yy73	12 V AC/DC	34.81.7.012.xxxx	93.60.0.024.7
39.00.0.024.yy73	24 V AC/DC	34.81.7.024.xxxx	93.60.0.024.7
39.00.0.125.yy73	(110...125)V AC/DC	34.81.7.060.xxxx	93.60.0.125.7
39.00.0.240.yy73	(24...240)V AC/DC	34.81.7.024.xxxx	93.60.0.240.7
39.00.8.230.yy73	(230...240)V AC	34.81.7.060.xxxx	93.60.8.230.7

MasterTIMER HazLoc - SSR version, Screw Socket Combinations

Interface Module Code	Input voltage	Relay	Socket
<i>MasterTIMER HazLoc</i>			
39.80.0.012.8273	12 V AC/DC	34.81.7.012.8240	93.68.0.024.7
39.80.0.024.8273	24 V AC/DC	34.81.7.024.8240	93.68.0.024.7
39.80.0.012.9073	12 V AC/DC	34.81.7.012.9024	93.68.0.024.7
39.80.0.024.9073	24 V AC/DC	34.81.7.024.9024	93.68.0.024.7

MasterTIMER HazLoc - SSR version, Push-in Socket Combinations

Interface Module Code	Input voltage	Relay	Socket
<i>MasterTIMER HazLoc</i>			
39.90.0.012.8273	12 V AC/DC	34.81.7.012.8240	93.69.0.024.7
39.90.0.024.8273	24 V AC/DC	34.81.7.024.8240	93.69.0.024.7
39.90.0.012.9073	12 V AC/DC	34.81.7.012.9024	93.69.0.024.7
39.90.0.024.9073	24 V AC/DC	34.81.7.024.9024	93.69.0.024.7

Example:

- .yy
- .7073 (0.1 A - 48 V DC)
- .9073 (5 A - 24 V DC)
- .8273 (0.75 A - 230 V AC)
- .xxxx
- .9024
- .7048
- .8240

Accessories



093.16



093.16.0



093.16.1

Approvals
(according to type):



16-way jumper link	093.16 (blue)	093.16.0 (black)	093.16.1 (red)
Rated values	36 A* - 250 V		
Possibility of multiple connection, side by side			

* Maximum rating of the jumper link. Each individual pole shall not exceed the 6 A limit of the interface to which it is connected.

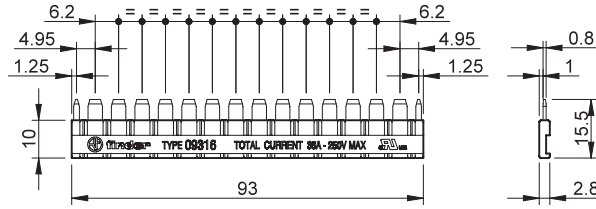

093.60



Dual-purpose plastic separator (1.8 mm or 6.2 mm separation)	093.60
---	--------

1. By breaking off the protruding ribs (by hand), the separator becomes only 1.8 mm thick; useful for the visual separation of different groups of interfaces, or necessary for the protective separation of different voltages of neighbouring interfaces, or for the protection of cut ends of jumper links.



2. Leaving the ribs in place provides 6.2 mm separation. Simply cutting (with scissors) the relevant segment(s) permits the interconnection across the separator of 2 different groups of interface relays, using the standard jumper link.

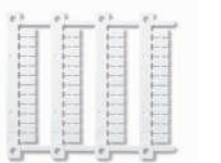
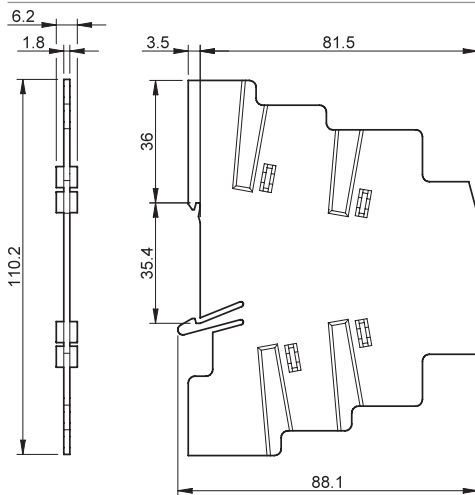

093.48

Sheet of marker tags, plastic, 48 tags, 6 x 10 mm	093.48
--	--------

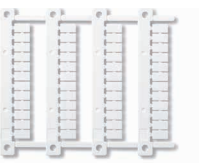

060.48

Sheet of marker tags (CEMBRE Thermal transfer printers), 48 tags, 6 x 12 mm	060.48
--	--------

Accessories



093.68.14.1
Approvals
(according to type):



Connected *MasterADAPTER*

MasterADAPTER		093.68.14.1
The <i>MasterADAPTER</i> permits the easy connection of A1/A2 terminals of up to 8 <i>MasterINTERFACE</i> modules to PLC outputs via a 14-Pole ribbon cable, plus simple 2-wire power supply connection ATEX Version.		
Technical data		
Rated current (per signal path)	A	1
Minimum required supply power	W	3
Nominal voltage (U _N)	V DC	24
Operating range	(0.8...1.1)U _N	
Control logic	Positive switching (to A1)	
Power supply status indication	Green LED	
Ambient temperature range	°C	-40...+70
Terminals for 24 V control logic		
Type of connector	14 pole, according to IEC 60603-13	
ATEX version	II 3G Ex nA IIC Gc	
Terminals for 24 V power supply		
Wire strip length	mm	9.5
Screw torque	Nm	0.5
Max. wire size		
	solid wire	mm ² 1 x 4 / 2 x 1.5
		AWG 1 x 12 / 2 x 16
	stranded wire	mm ² 1 x 2.5 / 2 x 1.5
		AWG 1 x 14 / 2 x 16

Wiring diagram

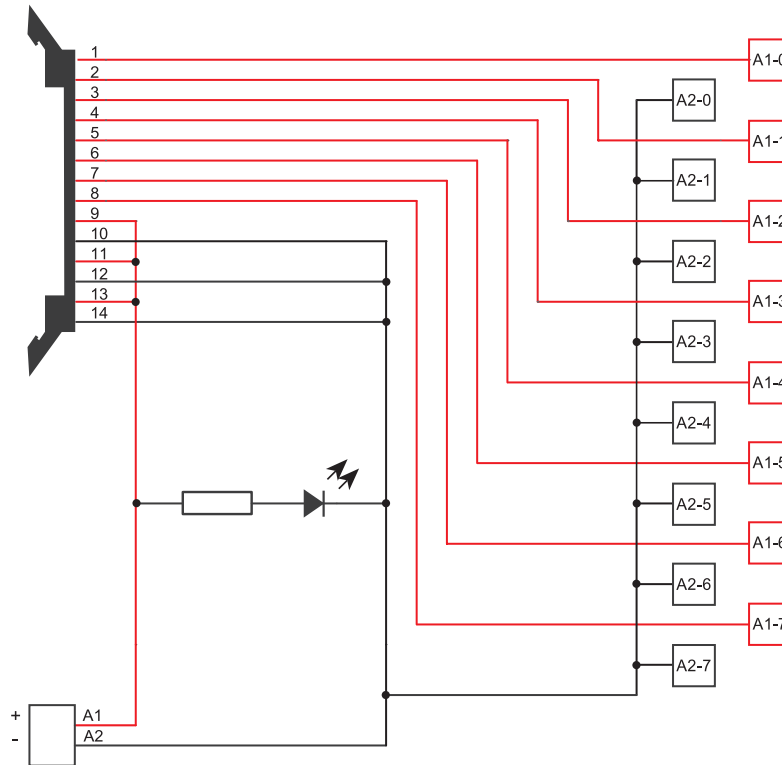

Low profile PCB relays 8 - 16 A IECEEx - ATEX - HazLoc

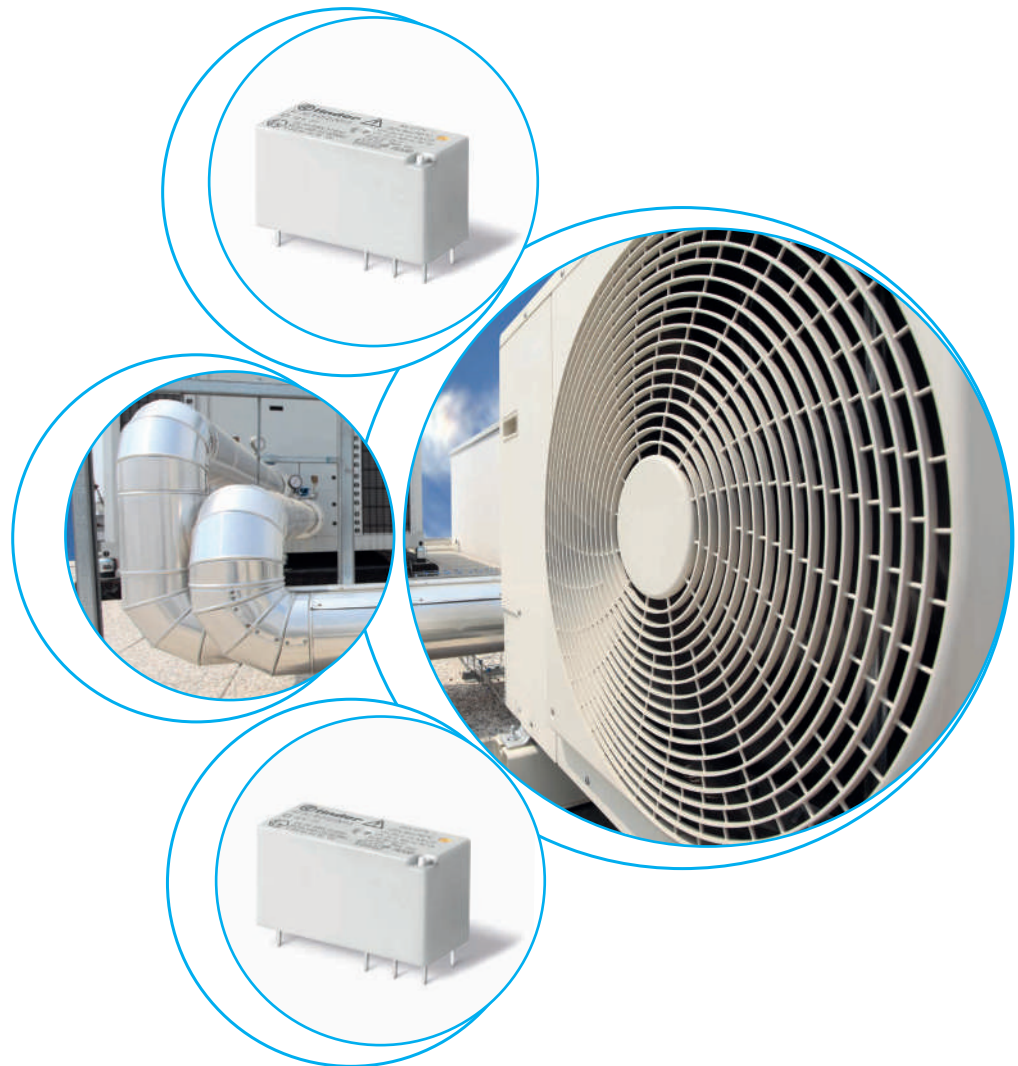

1 & 2 Pole - Low profile (15.7 mm height)

Type 41.52

- 2 Pole 8 A (5.0 mm pin pitch)

Type 41.61

- 1 Pole 16 A (5.0 mm pin pitch)

PCB mount

- direct

- DC coils
- 8 mm, 6 kV (1.2/50 μ s) isolation, coil-contacts
- Cadmium Free contact materials
- Versions compliant with IECEx, ATEX (Ex ec nC), HazLoc Class I Div. 2, Groups A, B, C, D - T4*

41.52



- 5.0 mm contact pin pitch
- 2 Pole 8 A
- PCB direct or via socket

41.61



- 5.0 mm contact pin pitch
- 1 Pole 16 A
- PCB direct or via socket

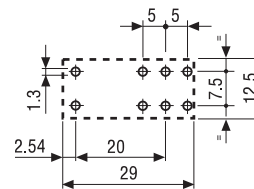
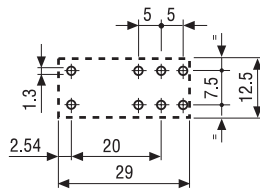
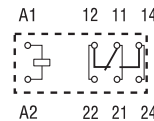
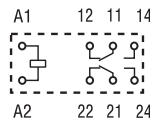

Copper side view

Copper side view

* Characteristics page 29

** See table temperature range on page 29

For outline drawing see page 29

Contact specification

Contact configuration		2 CO (DPDT) - 2 NO (DPST)	1 CO (SPDT) - 1 NO (SPST)
Rated current	A	8	16
Rated voltage	V AC	277	277
Rated load AC1	VA	2215	4430
Rated load AC15 (230 V AC)	VA	400	750
Single phase motor rating (230 V AC)	kW	0.3	0.5
Breaking capacity DC1: 32 V	A	5	5
Minimum switching load	mW (V/mA)	300 (5/5)	300 (5/5)
Standard contact material		AgNi	AgNi

Coil specification

Nominal voltage (U_N)	V DC	5 - 6 - 12 - 24 - 48 - 60 - 110	5 - 6 - 12 - 24 - 48 - 60 - 110
Rated power AC/DC	W	0.52	0.52
Operating range	DC	(0.7...1.5) U_N	(0.7...1.5) U_N
Holding voltage	DC	0.4 U_N	0.4 U_N
Must drop-out voltage	DC	0.1 U_N	0.1 U_N

Technical data

Mechanical life DC	cycles	10 · 10 ⁶	10 · 10 ⁶
Electrical life at rated load AC1	cycles	60 · 10 ³	50 · 10 ³
Operate/release time	ms	8/6	8/6
Insulation between coil and contacts (1.2/50 μ s)	kV	6 (8 mm)	6 (8 mm)
Dielectric strength between open contacts	V AC	1000	1000
Ambient temperature range DC	°C	-40...+85**	-40...+85**
Environmental protection		RT III	RT III

Approvals (according to type)



Ordering information

Electromechanical relay (EMR)

Example: 41 series low-profile PCB relay, 2 CO (DPDT), 24 V DC coil.

A

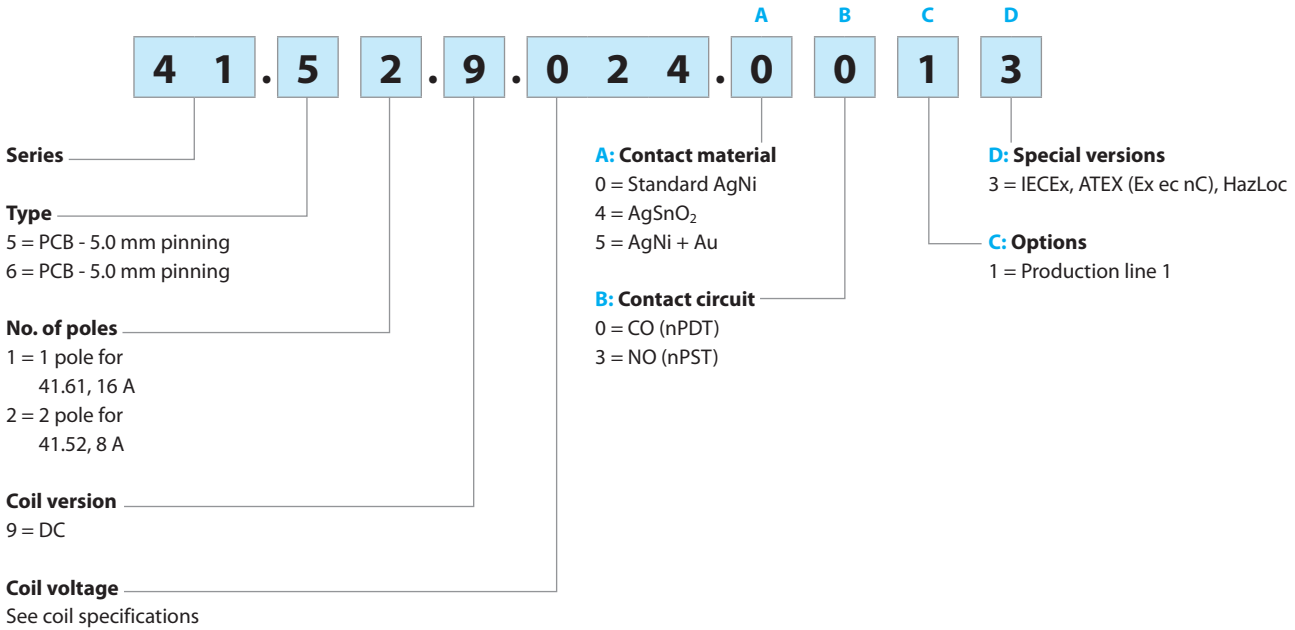

Selecting features and options: only combinations in the same row are possible.
Preferred selections for best availability are shown in **bold**.

Type	Coil version	A	B	C	D
41.52	DC	0 - 5	0 - 3	1	3
41.61	DC	0 - 4	0 - 3	1	3

Electromechanical relay

A

Technical data

Insulation according to EN 61810-1					
		1 pole		2 pole	
Nominal voltage of supply system	V AC	230/400		230/400	
Rated insulation voltage	V AC	250	400	250	400
Pollution degree		3	2	3	2
Insulation between coil and contact set					
Type of insulation		Reinforced (8 mm)		Reinforced (8 mm)	
Overvoltage category		III		III	
Rated impulse voltage	kV (1.2/50 µs)	6		6	
Dielectric strength	V AC	4000		4000	
Insulation between adjacent contacts					
Type of insulation		—		Basic	
Overvoltage category		—		III	
Rated impulse voltage	kV (1.2/50 µs)	—		4	
Dielectric strength	V AC	—		2000	
Insulation between open contacts					
Type of disconnection		Micro-disconnection		Micro-disconnection	
Dielectric strength	V AC/kV (1.2/50 µs)	1000/1.5		1000/1.5	
Insulation between coil terminals					
Rated impulse voltage (according to EN 61180)	kV (1.2/50 µs)	2			
Other data					
Bounce time: NO/NC	ms	4/6 (monostable)			
Vibration resistance (5...55)Hz: NO/NC	g	15/2 (monostable)			
Shock resistance	g	16 (monostable)			
Power lost to the environment	without contact current	W	0.4 (monostable)		
	with rated current	W	1.2 (41.52)	1.8 (41.61)	
Recommended distance between relays mounted on PCB	mm	≥ 5			

Contact specification

F 41 - Electrical life (AC) v contact current (monostable)

Type 41.61

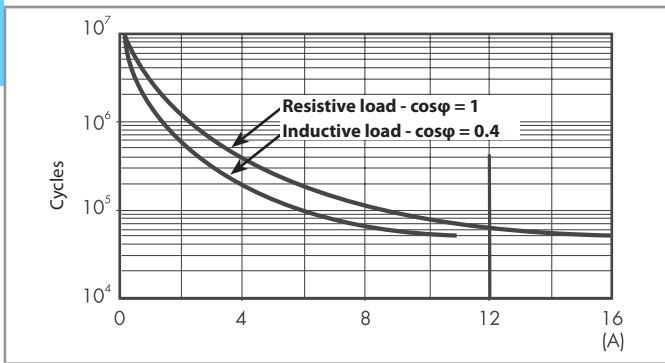

F 41 - Electrical life (AC) v contact current (monostable)

Type 41.52

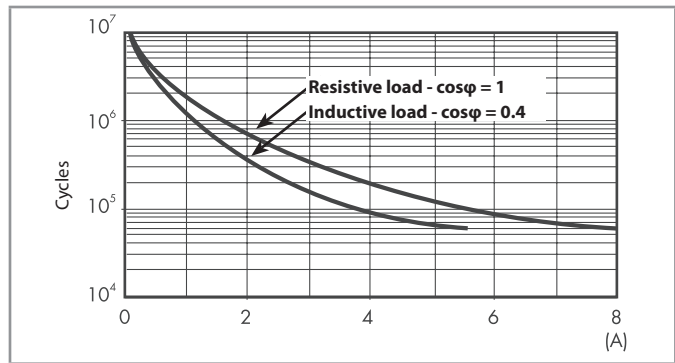

H 41 - Maximum DC1 breaking capacity

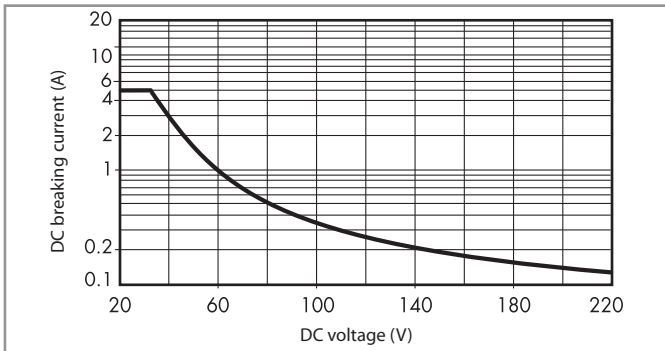

- When switching a resistive load (DC1) having voltage and current values under the curve, an electrical life of $\geq 100 \cdot 10^3$ can be expected.
- In the case of DC13 loads, the connection of a diode in parallel with the load will permit a similar electrical life as for a DC1 load.
Note: the release time for the load will be increased.

Coil specifications

DC coil data

Nominal voltage U_N V	Coil code	Operating range		Resistance R Ω	Rated coil consumption I at U_N mA
		U_{min} V	U_{max} V		
5	9.005	3.5	7.5	62	80
6	9.006	4.2	9	90	66.7
12	9.012	8.4	18	360	33.3
24	9.024	16.8	36	1440	16.7
48	9.048	33.6	72	5760	8.3
60	9.060	42	90	9000	6.6
110	9.110	77	165	24200	4.5

R 41 - DC coil operating range v ambient temperature

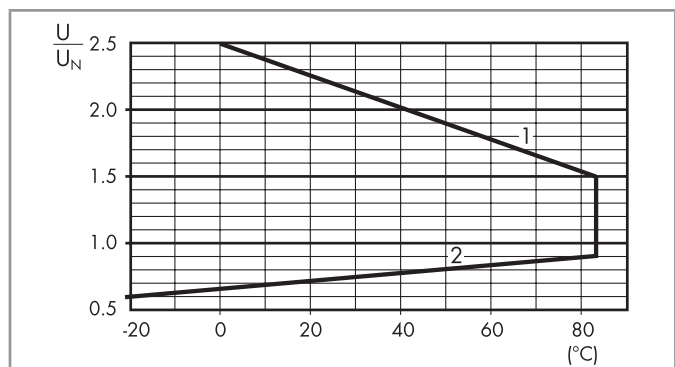

- 1 - Max. permitted coil voltage.
- 2 - Min. pick-up voltage with coil at ambient temperature.

IECEx - ATEX - HazLoc: Nominal current and ambient temperature

Type		41.52...13	41.61...13	
Approval	Ambient temperature	Contact configuration	2 CO/NO	1 CO/NO
IECEx - EX	-20...+85 °C (105 °C service temperature)	Rated voltage	277 V AC	277 V AC
		Rated current	8 A	16 A
		Breaking capacity DC1: 32 V DC	5 A	5 A
HazLoc	-20...+70 °C (105 °C service temperature)	Rated voltage	277 V AC	277 V AC
		Rated current	8 A	16 A
		Breaking capacity DC1: 32 V DC	5 A	5 A
	-20...+85 °C (105 °C service temperature)	Rated voltage	—	277 V AC
Rated current		—	10 A	

Markings - ATEX, IECEx and HazLoc versions

ATEX (UL 23 ATEX 3142 U):	II 3 G	
IECEx (IECEx ULD 23.0038 U):	Ex nC IIC Gc	
Haz.Loc. (E539562):	CI I, Div2, Gr A, B, C, D, T4 CI I, Zn 2, AEx nC IIC Ex nC IIC Gc U	
Specific marking of explosion protection		
II Component for surface plant (different from mines)		
3 Category 3: normal level of protection		
G - CI I Explosive atmosphere due to presence of combustible gas vapour or mist		
Div 2 - Zn 2 Hazardous explosive concentration presence just in case of fault		
Ex nC - AEx nC Sealed device		
IIC - Gr A, B, C, D Gas group		
T4 Temperature class		
Gc Device protection level		
UL 23 ATEX 3142 U - IECEx ULD 23.0038 U - E539562		
UL - ULD: ID of the notified body which issues the type certificate		
23: year of issue of the certificate		
3142 - 0013: number of the type certificate		
E539562: UL file number		
U: components		
Zyy: production batch identification		
Z: year, yy: week		

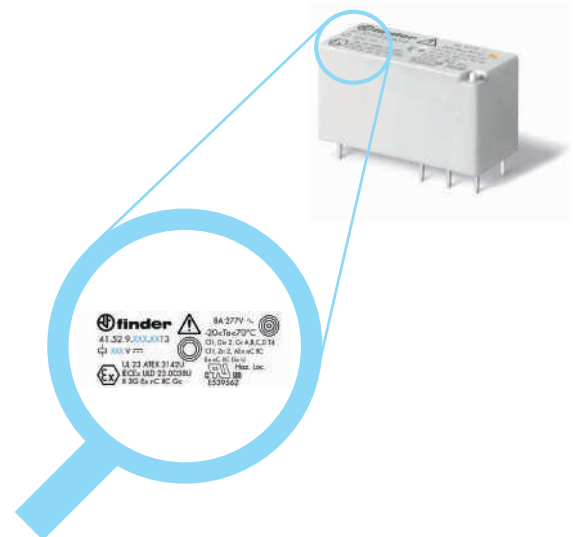

Outline drawings

Types 41.52/61

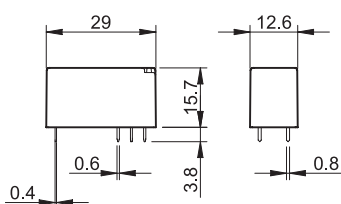

Types 41.52.6.xxx/41.61.6.xxx

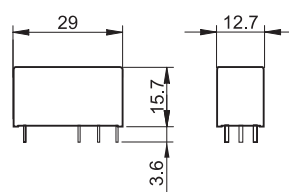

Relay interface modules 6 - 8.5 - 10 A IECEX - ATEX - HazLoc

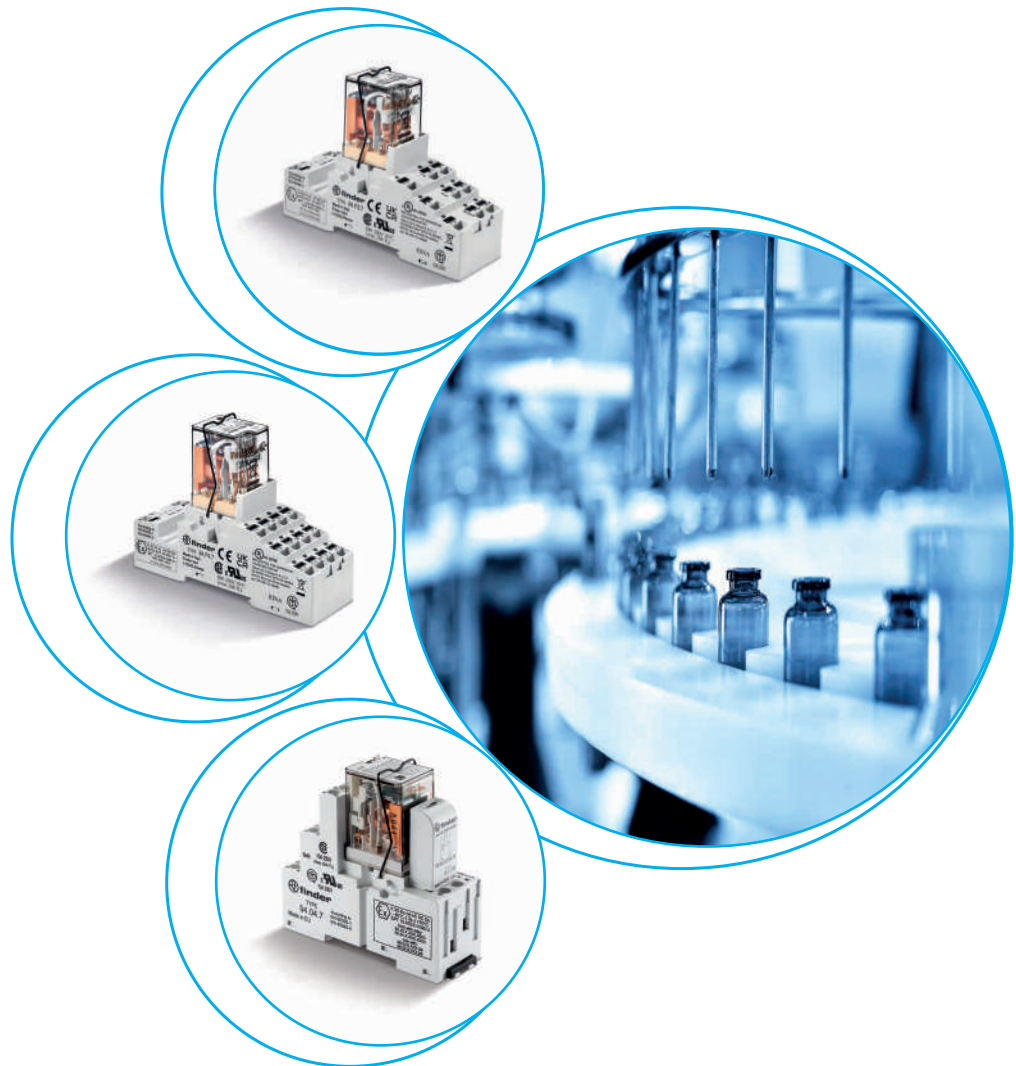

2, 3 or 4 CO relay interface modules IECEx, 31 mm wide with Push-in terminals
IECEx - ATEX certification: II 3G Ex ec nC IIC Gc
HazLoc certification: Class I Div. 2
Groups A, B, C, D - T5*

Type 58.P2 - x00x

- 2 CO 10 A
- Push-in terminals sockets

Type 58.P3 - x00x

- 3 CO 8.5 A
- Push-in terminals sockets

Type 58.P4 - x00x

- 4 CO 6 A
- Push-in terminals sockets

- AC coils or DC coils
- Mechanical indicator - optional on 2 & 4 CO types
- Identification label
- Cadmium Free contacts
- Complies with:
 - EN IEC 60079-0:2018;
 - EN IEC 60079-7:2015+A1:2018;
 - EN 60079-15:2010;
 - EN IEC 60079-15:2019
- 35 mm rail (EN 60715) mounting

58.P3/58.P4
Push-in terminals



* Characteristics page 36, 37

For outline drawing see page 39

Contact specification

Contact configuration	3 CO (3PDT)	4 CO (4PDT)
Rated current/Maximum peak current	A 8.5/20	6/15
Rated voltage/Maximum switching voltage	V AC 250/400	250/250
Rated load AC1	VA 2125	1500
Rated load AC15 (230 V AC)	VA 500	350
Single phase motor rating (230 V AC)	kW 0.55	0.24
Breaking capacity DC1: 24/110/220 V	A 8.5/0.5/0.25	6/0.5/0.25
Minimum switching load	mW (V/mA) 300 (5/5)	300 (5/5)
Standard contact material	AgNi	AgNi

Coil specification

Nominal voltage (U _N)	V AC (50/60 Hz)	12 - 24 - 48 - 110 - 120 - 230	12 - 24 - 48 - 110 - 120 - 230
	V DC	12 - 24 - 48 - 125	12 - 24 - 48 - 125
Rated power AC/DC	VA (50 Hz)/W	1.5/1	1.5/1
Operating range	AC	(0.8...1.1)U _N	(0.8...1.1)U _N
	DC	(0.8...1.1)U _N	(0.8...1.1)U _N
Holding voltage	AC/DC	0.8 U _N / 0.5 U _N	0.8 U _N / 0.5 U _N
Must drop-out voltage	AC/DC	0.2 U _N / 0.1 U _N	0.2 U _N / 0.1 U _N

Technical data

Mechanical life AC/DC	cycles	20 · 10 ⁶ / 50 · 10 ⁶	20 · 10 ⁶ / 50 · 10 ⁶
Electrical life at rated load AC1	cycles	200 · 10 ³	150 · 10 ³
Operate/release time	ms	10/5 (AC) - 10/15 (DC)	11/3 (AC) - 11/15 (DC)
Insulation between coil and contacts (1.2/50 μs)	kV	3.6	3.6
Dielectric strength between open contacts	V AC	1000	1000
Ambient temperature range	°C	-40...+70	-40...+70
Protection category		IP 20	IP 20

Approvals (according to type)

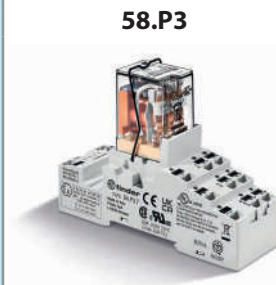
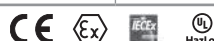

58.P3

- 3 CO 8.5 A
- IECEx, ATEX, Hazardous Location compliant
- Push-in terminals

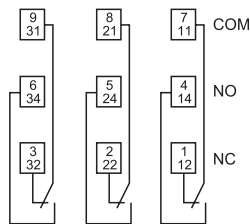

Example: AC



58.P4

- 4 CO 6 A
- IECEx, ATEX, Hazardous Location compliant
- Push-in terminals

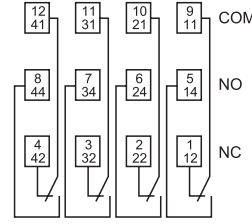

Example: DC

2, 3 or 4 CO relay interface modules IECEx,
27 mm wide with Box clamp

IECEx - ATEX certification: II 3G Ex ec nC IIC Gc

HazLoc certification: Class I Div. 2

Groups A, B, C, D - T5*

Type 58.32 - x0xx

- 2 CO 10 A
- Box clamp

Type 58.33 - x0xx

- 3 CO 8.5 A
- Box clamp

Type 58.34 - x0xx

- 4 CO 6 A
- Box clamp

- AC coils or DC coils
- Supply status indication and EMC coil suppression module as standard
- Mechanical indicator - optional on 2 & 4 CO types
- Identification label
- Cadmium Free contacts
- Complies with:
EN IEC 60079-0:2018;
EN IEC 60079-7:2015+A1:2018;
EN 60079-15:2010;
EN IEC 60079-15:2019
- 35 mm rail (EN 60715) mounting

58.32/58.34 - x0xx
Box clamp



* Characteristics page 36, 37

For outline drawing see page 39

58.32 - x0xx



- 2 CO 10 A
- Box clamp
- IECEx, ATEX, Hazardous Location compliant

58.34 - x0xx

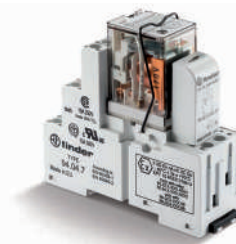

- 4 CO 6 A
- Box clamp
- IECEx, ATEX, Hazardous Location compliant

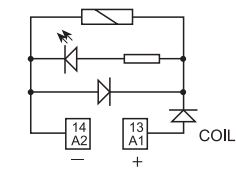
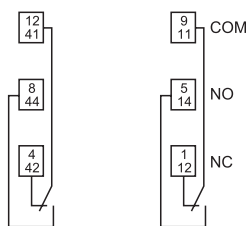

Example: DC

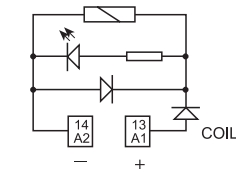
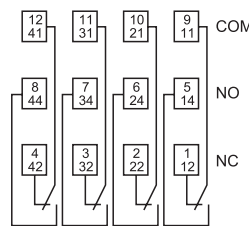

Example: DC

Contact specification

Contact configuration		2 CO (DPDT)	4 CO (4PDT)
Rated current/Maximum peak current**	A	10/20	6/15
Rated voltage/ Maximum switching voltage	V AC	250/400	250/250
Rated load AC1	VA	2500	1500
Rated load AC15 (230 V AC)	VA	500	350
Single phase motor rating (230 V AC)	kW	0.55	0.24
Breaking capacity DC1: 24/110/220 V	A	10/0.25/0.12	6/0.25/0.12
Minimum switching load	mW (V/mA)	300 (5/5)	300 (5/5)
Standard contact material		AgNi	AgNi

Coil specification

Nominal voltage (U _N)	V AC (50/60 Hz)	12 - 24 - 48 - 110 - 120 - 230	12 - 24 - 48 - 110 - 120 - 230
	V DC	12 - 24 - 48 - 125	12 - 24 - 48 - 125
Rated power AC/DC	VA (50 Hz)/W	1.5/1	1.5/1
Operating range	AC	(0.8...1.1)U _N	(0.8...1.1)U _N
	DC	(0.8...1.1)U _N	(0.8...1.1)U _N
Holding voltage	AC/DC	0.8 U _N / 0.5 U _N	0.8 U _N / 0.5 U _N
Must drop-out voltage	AC/DC	0.2 U _N / 0.1 U _N	0.2 U _N / 0.1 U _N

Technical data

Mechanical life AC/DC	cycles	20 · 10 ⁵ / 50 · 10 ⁶	20 · 10 ⁵ / 50 · 10 ⁶
Electrical life at rated load AC1	cycles	150 · 10 ³	150 · 10 ³
Operate/release time	ms	11/3 (AC) - 11/15 (DC)	11/3 (AC) - 11/15 (DC)
Insulation between coil and contacts (1.2/50 μs)	kV	3.6	3.6
Dielectric strength between open contacts	V AC	1000	1000
Ambient temperature range	°C	-40...+70**	-40...+70**
Protection category		IP 20	IP 20

Approvals (according to type)

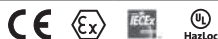

** See page 36 for details of rated current and ambient temperature approval characteristic

Ordering information IECEx, ATEX and Hazardous Location versions

Example: 58 series, 35 mm rail (EN 60715), Box clamp terminal interface module, 4 CO, 120 V AC, green LED, mechanical indicator, ATEX and HazLoc Version.

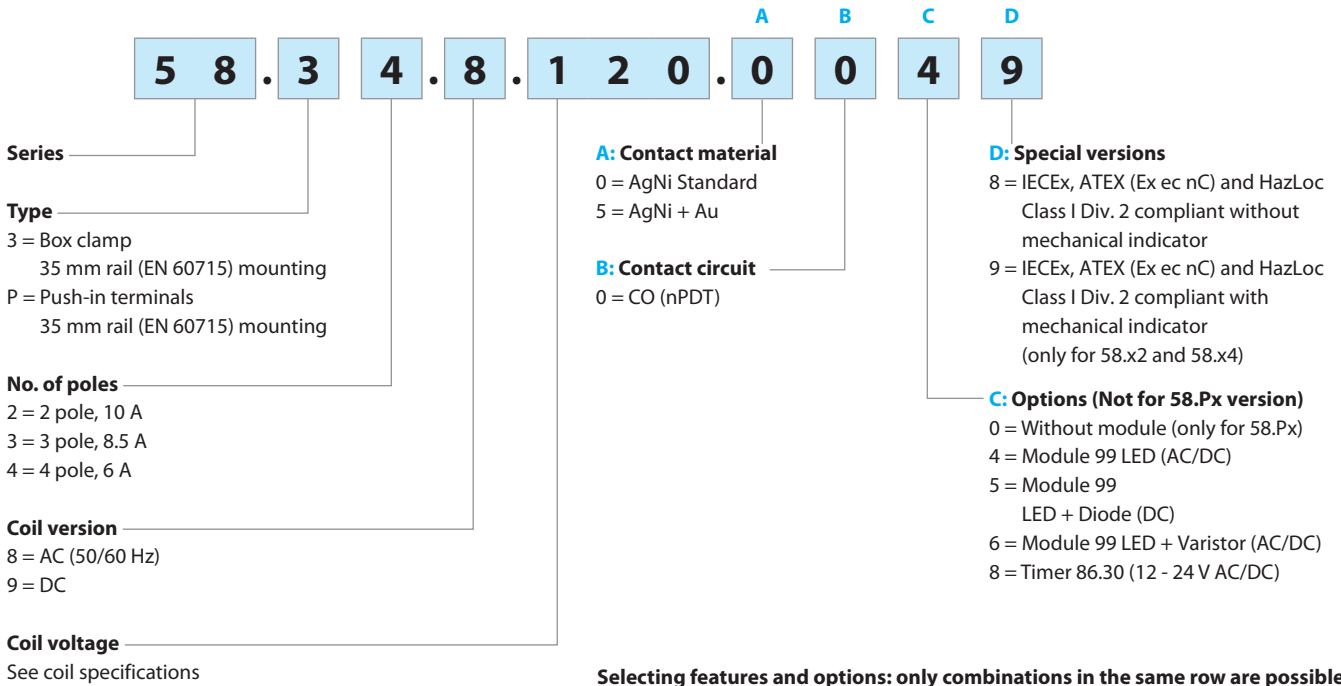

Selecting features and options: only combinations in the same row are possible.

Type	Coil version	A	B	C	D
58.3x	AC/DC	0 - 5	0	4 - 5 - 6 - 8	8 - 9
58.33	AC/DC	0 - 5	0	4 - 5 - 6 - 8	8
58.Px	AC/DC	0 - 5	0	0	8 - 9
58.P3	AC/DC	0 - 5	0	0	8

Technical data

Insulation

Insulation according to EN 61810-1	insulation rated voltage	V	400 (2-3 pole)	250 (4 pole)
	rated impulse withstand voltage	kV	3.6 (2-3 pole)	2.5 (4 pole)
	pollution degree		2	2
	overvoltage category		III	II

Insulation between coil and contacts (1.2/50 µs)	kV	3.6
Dielectric strength between open contacts	V AC	1000
Dielectric strength between adjacent contacts	V AC	2000 (58.32, 58.P3)
		1550 (58.34, 58.P4)

Insulation between coil terminals

Rated impulse voltage (according to EN 61180)	kV (1.2/50 µs)	4
---	----------------	---

Other data

Bounce time: NO/NC	ms	1/3			
Vibration resistance (10...55)Hz: NO/NC	g	6/6			
Power lost to the environment	without contact current	W	1		
	with rated current	W	3 (58.32, 58.34, 58.P4)		
		58.32/33/34 (Box clamp)	58.P2/P3/P4 (Push-in terminals)		
Wire strip length	mm	8			
 Screw torque	Nm	0.5			
Min. wire size	mm ²	solid cable	stranded cable	solid cable	stranded cable
		0.5	0.5	0.5	0.5
		AWG 21	21	21	21
Max. wire size	mm ²	solid cable	stranded cable	solid cable	stranded cable
		1 x 6 / 2 x 2.5	1 x 4 / 2 x 2.5	2 x 1.5 / 1 x 2.5	2 x 1.5 / 1 x 2.5
		AWG 1 x 10 / 2 x 14	1 x 12 / 2 x 14	2 x 16 / 1 x 14	2 x 16 / 1 x 14

IECEx, ATEX and HazLoc - Electrical characteristics

Max current @ 70 °C (max temperature IECEx, ATEX applications)	Single piece mount	> 1 piece mount of 5 interfaces
Type 58.x2	A 10	7
Type 58.x3	A 8.5	6
Type 58.x4	A 6	4
Max current @ 40 °C (max temperature Hazloc applications)	Single piece mount	> 1 piece mount of 5 interfaces
Type 58.x2	A 9	9
Type 58.x3	A 7	7
Type 58.x4	A 5	5

Terminals

Wire strip length	mm	8	
 Screw torque	Nm	0.5	
Wire size	mm ²	solid cable	stranded cable
		1 x 2.5 / 2 x 1.5	1 x 2.5 / 2 x 1.5
		AWG 1 x 12 / 2 x 16	1 x 12 / 2 x 16

Markings - IECEx, ATEX versions - II 3G Ex ec nC IIC Gc

MARKING	
	Specific marking of explosion protection
II	Component for surface plant (different from mines)
3	Category 3: normal level of protection
GAS	G Explosive atmosphere due to presence of combustible gas vapour or mist
	Ex ec Increased Safety
	Ex nC Sealed device (type of protection for category 3G)
	IIC Gas group
	Gc Equipment Protection Level



Markings - Hazardous Location Class I Div. 2 Groups A, B, C, D - T5 and other data

HazLoc Class I Div. 2 Group A, B, C, D - T5		Meaning
Class I		Areas in which flammable gases and vapours may be present
Div. 2		Low probability to find ignitable hazardous concentration because it is typically present in closed system from which can escape through breakdown or accidental rupture
Group A, B, C, D		Kind of combustible, flammable gases and vapours can be in the atmosphere
Permissible Surface temperature		
T5	100 °C	212 °F

IECEx, ATEX and HazLoc - Electrical characteristics and ambient temperature of work

Interface Code	IECEx-ATEX current [A] rating -40...+70 °C (Service Temperature 115°C)		HazLoc current [A] rating -25...+40 °C group mounting	
	Single mounting	Group mounting	24 V DC	230 V AC
58.32.x.xxx	10	7	9	9
58.33.x.xxx	8.5	6	5	7
58.34.x.xxx	6	4	5	5
58.P2.x.xxx	10	7	9	9
58.P3.x.xxx	8.5	6	5	7
58.P4.x.xxx	6	4	5	5

If used with 86 modular timer, the ambient temperature range is -20...+50 °C

Contact specification

F 58 - Electrical life (AC) v contact current
3 pole relays

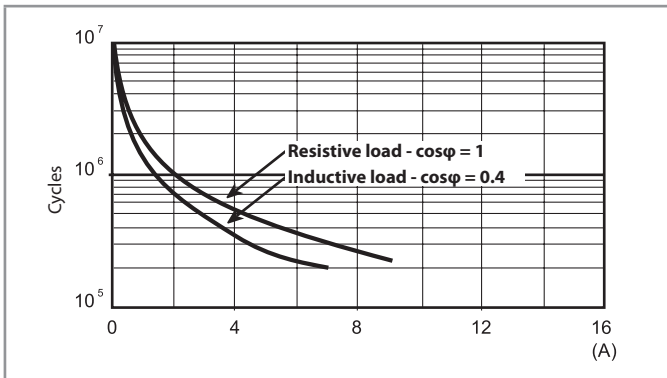

F 58 - Electrical life (AC) v contact current
4 pole relay

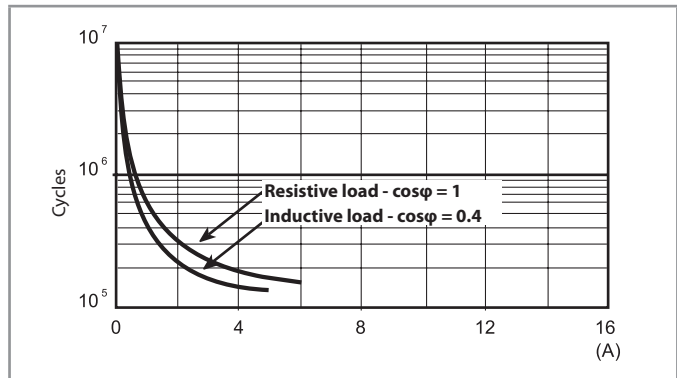

H 58 - Maximum DC1 breaking capacity

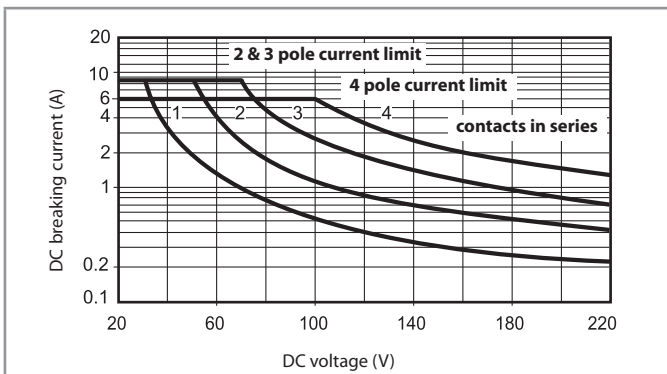

- When switching a resistive load (DC1) having voltage and current values under the curve, an electrical life of $\geq 100 \cdot 10^3$ can be expected.
- In the case of DC13 loads, the connection of a diode in parallel with the load will permit a similar electrical life as for a DC1 load.
Note: the release time for the load will be increased.

Coil specifications

DC coil data

Nominal voltage U_N V	Coil code	Operating range		Resistance R Ω	Rated coil absorption I at U_N mA
		U_{min} V	U_{max} V		
12	9.012	9.6	13.2	140	86
24	9.024	19.2	26.4	600	40
48	9.048	38.4	52.8	2400	20
125	9.125	100	138	17300	7.2

AC coil data

Nominal voltage U_N V	Coil code	Operating range		Resistance R Ω	Rated coil absorption I at U_N (50 Hz) mA
		U_{min} V	U_{max} V		
12	8.012	9.6	13.2	50	97
24	8.024	19.2	26.4	190	53
48	8.048	38.4	52.8	770	25
110	8.110	88	121	4000	12.5
120	8.120	96	132	4700	12
230	8.230	184	253	17000	6

R 58 - DC coil operating range v ambient temperature

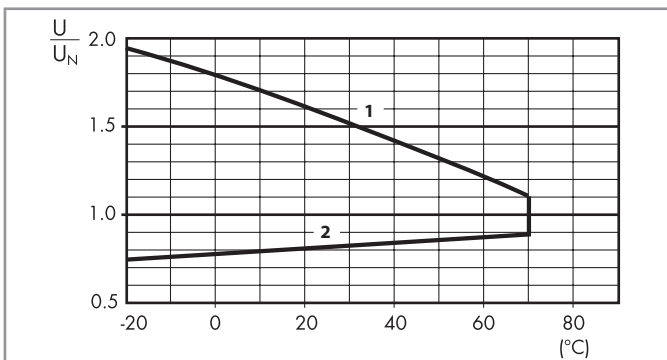

R 58 - AC coil operating range v ambient temperature

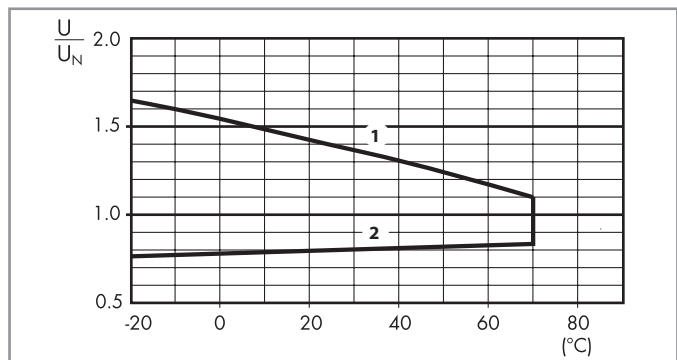

- 1 - Max. permitted coil voltage.
2 - Min. pick-up voltage with coil at ambient temperature.

- 1 - Max. permitted coil voltage.
2 - Min. pick-up voltage with coil at ambient temperature.

Combinations

Certain relay/socket combinations

Code	Type of socket	Type of relay	Module	Retaining clip
58.P2	94.P3.7	55.32	—	094.71
58.P3	94.P3.7	55.33	—	094.71
58.P4	94.P4.7	55.34	—	094.71
58.32	94.02.7	55.32	99.02	094.71
58.33	94.03.7	55.33	99.02	094.71
58.34	94.04.7	55.34	99.02	094.71

Outline drawings

Type 58.32
Box clamp

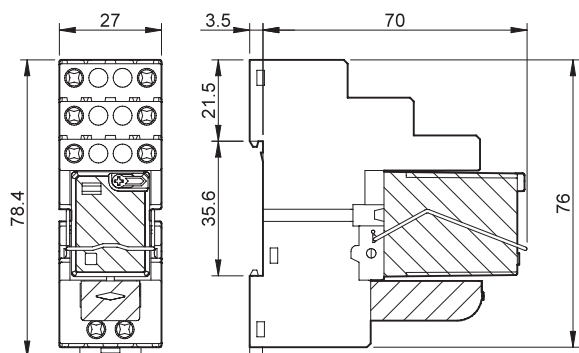

Type 58.34
Box clamp

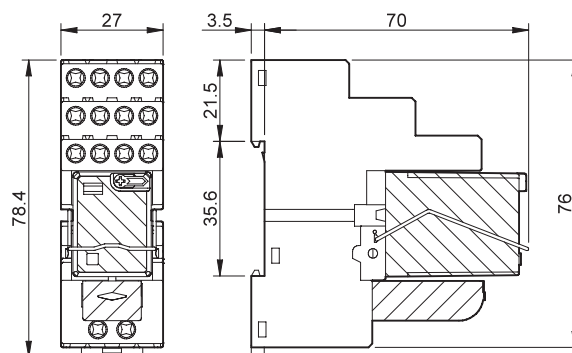

Type 58.P3
Push-in terminals

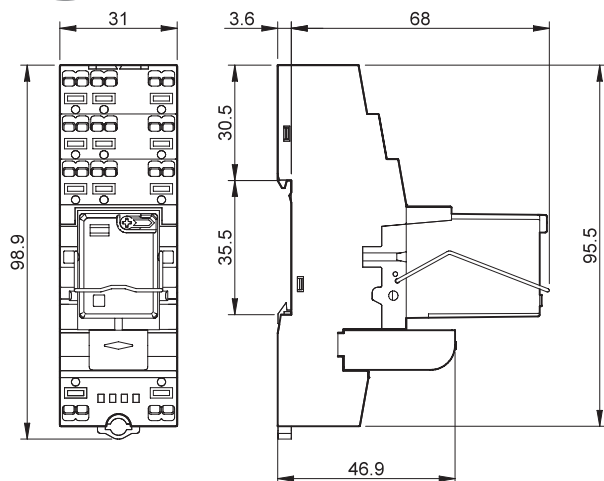

Type 58.P4
Push-in terminals

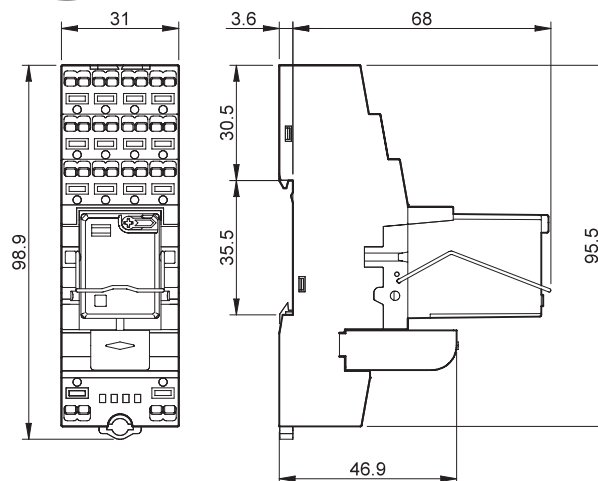

Accessories

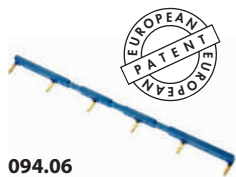

094.06

6-way jumper link for type 58.32, 58.34	094.06 (blue)	094.06.0 (black)
Rated values	10 A - 250 V	

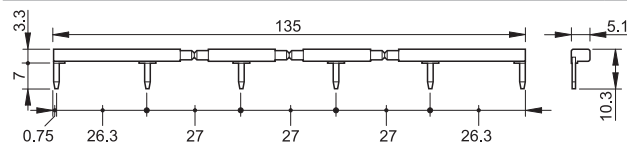

060.48

Sheet of marker tags , plastic, 48 tags, 6 x 12 mm	060.48
---	--------

Packaging codes

How to code and identify retaining clip and packaging options for sockets.

Example:

5 8 . P 4 . 9 . 0 2 4 . 0 0 0 8 S M A

A Standard packaging
B Blister packaging

SM Metallic retaining clip

Power relays 25 - 30 A ATEX - HazLoc



2 Pole changeover (DPDT) or 2 NO (DPST) 30 A ATEX - HazLoc Power Relay

Type 66.82-xx03

- Faston 250 connections and Flange mount

- Reinforced insulation between coil and contacts according to EN 60335-1; 8 mm creepage and clearance distances
- AC coils & DC coils
- Cadmium Free option available
- **ATEX** compliant (Ex ec nC)
- **HazLoc** Class I Div. 2 Group A, B, C, D - T4 - T5 - T6

66.82-xx03



- 30 A rated contacts
- Flange mount
- Faston 250 connections

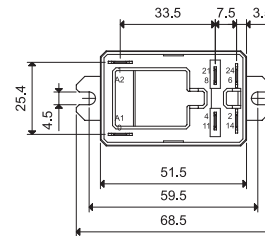
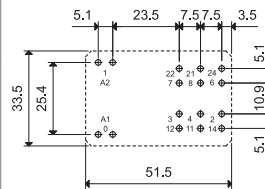
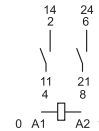
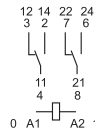

2 CO (nPDT)

2 NO (nPST)

* Contact material AgSnO₂; 120 A (5 ms)

For outline drawing see page 50

Contact specification

Contact configuration		2 CO (nPDT) or 2 NO (nPST)
Rated current/Maximum peak current	A	30/50* (NO) - 10/20 (NC)
Rated voltage/Maximum switching voltage	V AC	250/440
Rated load AC1	VA	7500 (NO) - 2500 (NC)
Rated load AC15 (230 V AC)	VA	1200 (NO)
Single phase motor rating (230 V AC)	kW	1.5 (NO)
Breaking capacity DC1: 24/110/220 V	A	25/0.7/0.3
Minimum switching load	mW (V/mA)	1000 (10/10)
Standard contact material		AgSnO ₂

Coil specification

Nominal voltage (U _N)	V AC (50/60 Hz)	6 - 12 - 24 - 110/115 - 120/125 - 230 - 240
	V DC	6 - 9 - 12 - 24 - 110 - 125
Rated power AC/DC	VA (50 Hz)/W	3.6/1.7
Operating range	AC	(0.8...1.1)U _N
	DC	(0.8...1.1)U _N
Holding voltage	AC/DC	0.8 U _N / 0.5 U _N
Must drop-out voltage	AC/DC	0.2 U _N / 0.1 U _N

Technical data

Mechanical life AC/DC	cycles	10 · 10 ⁶
Electrical life at rated load AC1	cycles	100 · 10 ³
Operate/release time	ms	8/10
Insulation between coil and contacts (1.2/50 μs)	kV	6 (8 mm)
Dielectric strength between open contacts	V AC	1500
Ambient temperature range	°C	-40...+70
Environmental protection		RT III

Approvals (according to type)



2 Pole for PCB or faston mounting ATEX - HazLoc Power Relay

Type 66.22-xx03S

- PCB mount 2 pole changeover (nPDT) 25 A or 2 pole NO (DPST) 25 A, 5 mm gap between PCB and relay base

Type 66.22-x603S

- PCB mount, 2 pole NO (nPST-NO) ≥ 1.5 mm contact gap 25 A Power relay, 5 mm gap between PCB and relay base

Type 66.82-x603

- Faston 250 connections and Flange mount, 2 pole NO (nPST-NO) ≥ 1.5 mm contact gap 30 A Power relay

- ≥ 1.5 mm contact gap (according to VDE 0126-1-1 for solar inverter applications)
- Reinforced insulation between coil and contacts according to EN 60335-1; 8 mm creepage and clearance distances
- DC coils
- Cadmium Free option available
- **ATEX** compliant (Ex ec nC)
- **HazLoc** Class I Div. 2 Group A, B, C, D - T4 - T5 - T6

66.22-xx03S



- PCB mount - bifurcated terminals

66.22-x603S



- PCB mount - bifurcated terminals
- 5 mm gap between PCB and relay base

66.82-x603



- Flange mount
- Faston 250 connections

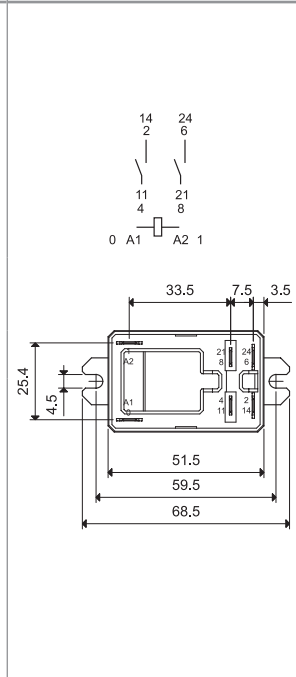
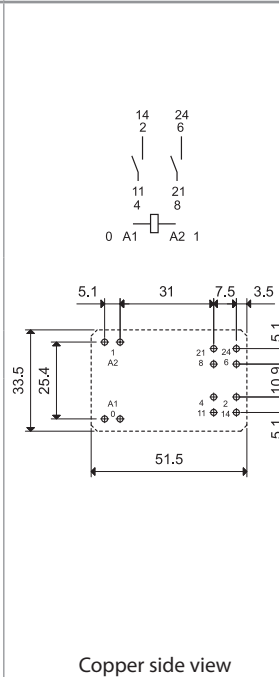
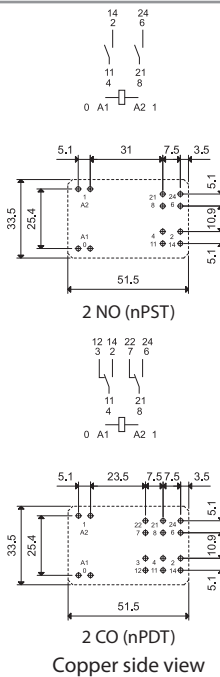

* Contact material AgSnO₂: 120 A (5 ms)

For outline drawing see page 50

Contact specification		66.22-xx03S	66.22-x603S	66.82-x603
Contact configuration		2 CO (nPDT) or 2 NO (nPST)	2 NO (DPST-NO)	2 NO (nPST-NO)
Rated current/Maximum peak current	A	25/50* (NO) - 10/20 (NC)	25/50*	30/50*
Rated voltage/Maximum switching voltage	V AC	250/440	250/440	250/440
Rated load AC1	VA	6250 (NO) - 2500 (NC)	6250	7500
Rated load AC15 (230 V AC)	VA	1200 (NO)	1200	1200
Single phase motor rating (230 V AC)	kW	1.5 (NO)	1.5	1.5
Breaking capacity DC1: 24/110/220 V	A	25/0.7/0.3 (NO)	25/1.2/0.5	25/0.7/0.3
Minimum switching load	mW (V/mA)	1000 (10/10)	1000 (10/10)	1000 (10/10)
Standard contact material		AgSnO ₂	AgSnO ₂	AgSnO ₂
Coil specification		6 - 9 - 12 - 24 - 110 - 125		
Nominal voltage (U _N)	V DC	6 - 9 - 12 - 24 - 110 - 125		
Rated power AC/DC	VA (50 Hz)/W	—/1.7	—/1.7	—/1.7
Operating range	AC	—	—	—
	DC	(0.7...1.1)U _N	(0.8...1.1)U _N	(0.8...1.1)U _N
Holding voltage	AC/DC	—/0.5 U _N	—/0.5 U _N	—/0.5 U _N
Must drop-out voltage	AC/DC	—/0.1 U _N	—/0.1 U _N	—/0.1 U _N
Technical data				
Mechanical life	cycles	10 · 10 ⁶	10 · 10 ⁶	10 · 10 ⁶
Electrical life at rated load AC1	cycles	100 · 10 ³	100 · 10 ³	100 · 10 ³
Operate/release time	ms	15/4	15/4	15/4
Insulation between coil and contacts (1.2/50 μs)	kV	6 (8 mm)	6 (8 mm)	6 (8 mm)
Dielectric strength between open contacts	V AC	2500	2500	2500
Ambient temperature range	°C	−40...+70	−40...+70	−40...+70
Environmental protection		RT III	RT III	RT III
Approvals (according to type)				

Ordering information

Example: 66 series relay, Faston 250 (6.3 x 0.8 mm) with top flange mount, 2 CO (DPDT) 30 A contacts, 24 V DC coil.

66.82.9024.A4003

Series — 66

Type — 8
2 = PCB
8 = Faston 250 (6.3 x 0.8 mm) with top flange mount

No. of poles — 2
2 = 2 pole 30 A
2 = 2 pole 25 A (S version)

Coil version — 9
8 = AC (50/60 Hz)
9 = DC

Coil voltage — 0
See coil specifications

A: Contact material
0 = AgCdO
1 = AgNi
4 = AgSnO₂

B: Contact circuit
0 = CO (nPDT)
3 = NO (nPST)
6 = NO (nPST), ≥ 1.5 mm contact gap

C: Options
0 = None

D: Special versions
3 = ATEX (Ex ec nC) and HazLoc Class I Div. 2 compliant

S = PCB version with 5 mm gap between PCB and relay base (only 66.22 ATEX/HazLoc versions)

ATEX/HAZLOC versions: only combinations in the same row are possible.

Type	Coil version	A	B	C	D
66.22...S	DC	0 - 1 - 4	0 - 3 - 6	0	3
66.82	AC - DC	0 - 1 - 4	0 - 3	0	3
	DC	0 - 1 - 4	6	0	3

Technical data

Insulation according to EN 61810-1

Nominal voltage of supply system	V AC	230/400	
Rated insulation voltage	V AC	400	
Pollution degree		3	
Insulation between coil and contact set			
Type of insulation		Reinforced (8 mm)	
Overvoltage category		III	
Rated impulse voltage	kV (1.2/50 μs)	6	
Dielectric strength	V AC	4000	
Insulation between adjacent contacts			
Type of insulation		Basic	
Overvoltage category		III	
Rated impulse voltage	kV (1.2/50 μs)	4	
Dielectric strength	V AC	2500	
Insulation between open contacts			
Type of disconnection		2 CO: Micro-disconnection 2 NO, ≥ 1.5 mm (x603 version): Full-disconnection*	
Overvoltage category		— II	
Rated impulse voltage	kV (1.2/50 μs)	— 2.5	
Dielectric strength	V AC/kV (1.2/50 μs)	1500/2 2500/2.5	
Insulation between coil terminals			
Rated impulse voltage (according to EN 61180)	kV (1.2/50 μs)	3.5	
Other data			
Bounce time: NO/NC	ms	7/10	
Vibration resistance (10...150)Hz: NO/NC	g	20/19	
Shock resistance	g	20	
Power lost to the environment	without contact current	W	2.3
	with rated current	W	5
Recommended distance between relays mounted on PCB	mm	≥ 10	

* Only in applications where over voltage category II is permitted. In applications of over voltage category III: Micro-disconnection.

Contact specification

F 66-1 Electrical life (AC) v contact current - Type 66.82
250 V (normally open contact)

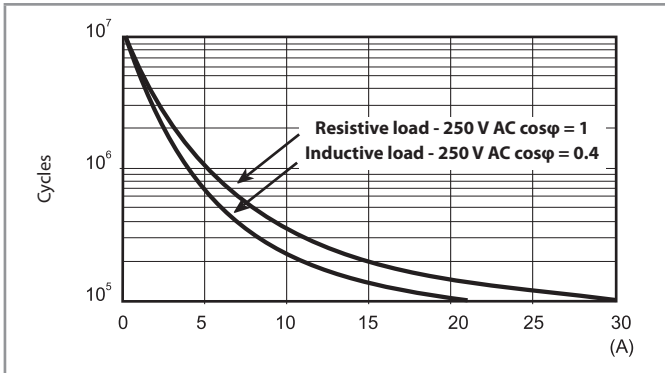

F 66-2 Electrical life (AC) v contact current - Type 66.82
440 V (normally open contact)

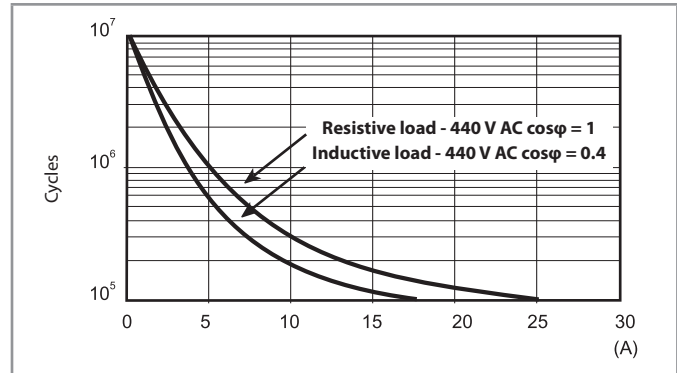

F 66-3 Electrical life (AC) v contact current - Type 66.22
250 V (normally open contact)

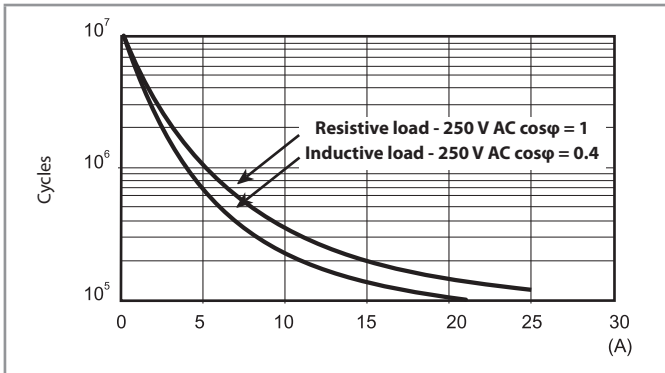

F 66-4 Electrical life (AC) v contact current - Type 66.22
440 V (normally open contact)

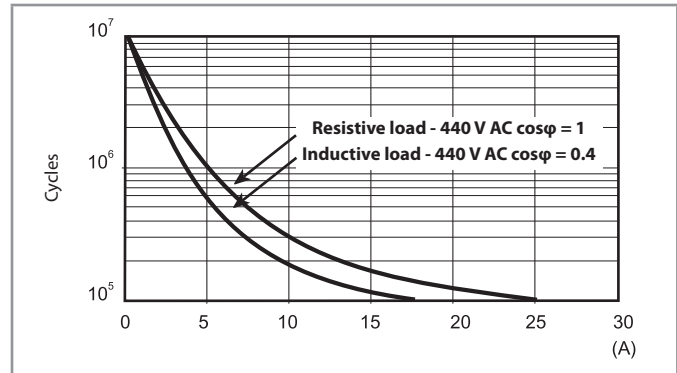

H 66-1 Maximum DC breaking capacity

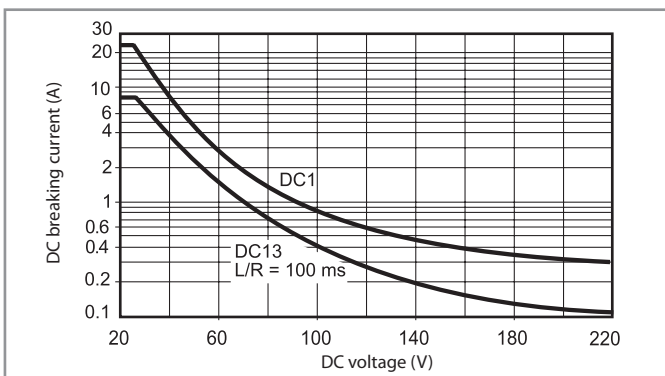

H 66-2 Maximum DC breaking capacity, x60x versions (> 1.5 mm contact gap)

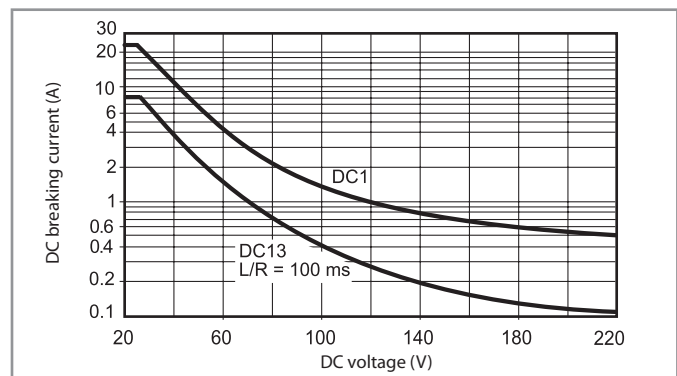

- When switching a resistive load (DC1) having voltage and current values under the curve, an electrical life of $\geq 100 \cdot 10^3$ can be expected.
- In the case of DC13 loads, the connection of a diode in parallel with the load will permit a similar electrical life as for a DC1 load.
Note: the release time for the load will be increased.

Coil specifications

DC coil data

Nominal voltage U_N	Coil code	Operating range		Resistance R	Rated coil Consumption I at U_N
		U_{min}	U_{max}		
V		V	V	Ω	mA
6	9.006	4.8	6.6	21	283
9	9.009	7.2	9.9	45	200
12	9.012	9.6	13.2	85	141
24	9.024	19.2	26.4	340	70.5
110	9.110	88	121	7000	15.7
125	9.125	100	138	9200	13.6

AC coil data

Nominal voltage U_N	Coil code	Operating range		Resistance R	Rated coil Consumption I at U_N (50 Hz)
		U_{min}	U_{max}		
V		V	V	Ω	mA
6	8.006	4.8	6.6	3	600
12	8.012	9.6	13.2	11	300
24	8.024	19.2	26.4	50	150
110/115	8.110	88	126	930	32.6
120/125	8.120	96	137	1050	30
230	8.230	184	253	4000	15.7
240	8.240	192	264	5500	15

R 66-1 DC coil operating range v ambient temperature

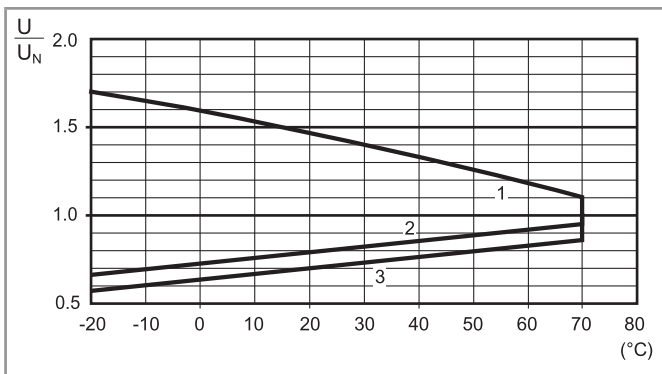

- 1 - Max. permitted coil voltage.
- 2 - Min. pick-up voltage with coil at ambient temperature.
- 3 - Min. pick-up voltage with coil at ambient temperature (66.22-x603S)

R 66-2 AC coil operating range v ambient temperature

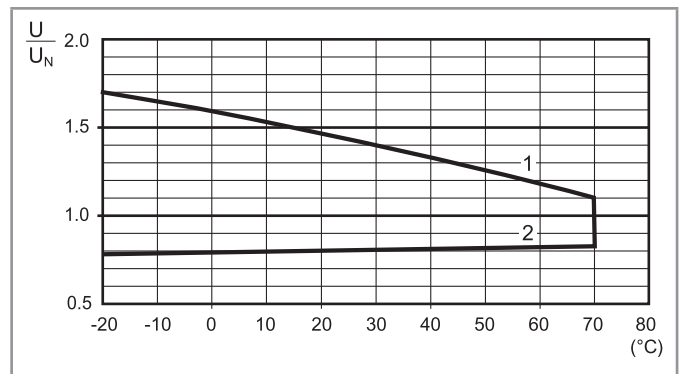

- 1 - Max. permitted coil voltage.
- 2 - Min. pick-up voltage with coil at ambient temperature.

Special condition for safe use

The component must be placed inside an enclosure that ensures a degree of protection IP 54 (or greater) according to standard EN 60529 and EN 60079-0 and that complies with the requirements of type of protection "Ex e" and EPL Gc (or better).

Wiring

The cross-section of conductors connected to the terminals, must be at least 4 mm² for the Type 66.82.

The connections must be made in compliance with the requirements of clause 4.2 of EN IEC 60079-7:2015+A1:2018.

Layout pcb

The minimum cross-section of the tracks of the printed circuit board must be 0.58 mm², while the width must be at least 4.01 mm for Type 66.22...S.

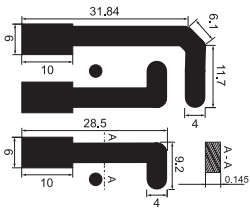

Markings - ATEX versions - ATEX, II 3G Ex ec nC IIC Gc

MARKING	
	Specific marking of explosion protection
II	Component for surface plant (different from mines)
3	Category 3: normal level of protection
GAS	G Explosive atmosphere due to presence of combustible gas vapour or mist
	Ex ec Increased safety (type of protection for category 3G)
	Ex nC Sealed device (type of protection for category 3G)
	IIC Gas group
	Gc Equipment Protection Level
-40 °C ≤ Ta ≤ +70 °C Ambient temperature	
EPTI 17 ATEX 0299 U EPTI: laboratory which issues the voluntary type certificate 17: year of issue of certificate 0299: number of CE type certificate	
U: Ex component	
Xyy: production batch identification (X year, yy week)	

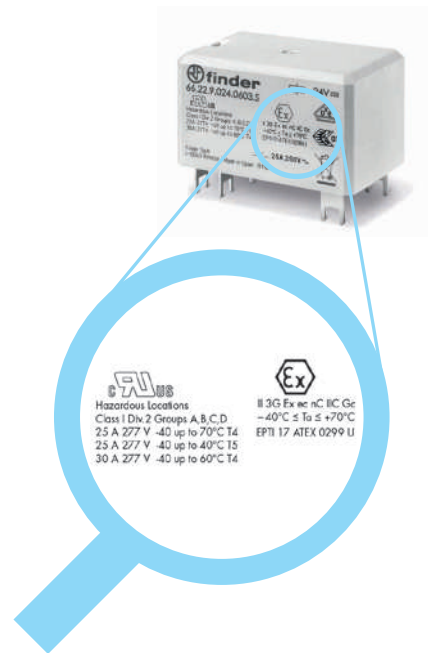

Markings - Hazardous Location Class I Div. 2 Groups A, B, C, D - T4 - T5 - T6 and other data

HazLoc Class I Div. 2 Group A, B, C, D - T4 - T5 - T6		Meaning
Class I		Areas in which flammable gases and vapours may be present
Div. 2		Low probability to find ignitable concentration of hazards because are typically present in containers or closed systems from which can escape through their accidental rupture or breakdown
Group A, B, C, D		Kind of combustible, flammable gases and vapours can be in the atmosphere.
Permissible Surface temperature		
T4	135 °C	275 °F
T5	100 °C	212 °F
T6	85 °C	185 °F

Model	T4				
	Type of load	Voltage	Current/Power	Temperature °C	Note
66.22	DC General Use Res Heating	30 V	25 A	-40...+70	only 66.xx.9.x6x3
66.22/66.82	AC Motor Starting, Discharge Lamps Break All lines	240 V	2 Hp	-40...+70	12FLA/69 LRA
		120 V	1 Hp	—	16FLA/96 LRA
		120 V	1/2 Hp	—	9.8FLA/58.8 LRA

Model	T5				
	Type of load	Voltage	Current/Power	Temperature °C	Note
66.22.x.xxx.xxx3S	DC General Use Res Heating	30 V	30 A	-40...+60	only 66.xx.9.x6x3
	AC Motor Starting, Discharge Lamps Break All lines	240 V	2 Hp	-40...+60	12FLA/69 LRA
		120 V	1 Hp		16FLA/96 LRA
		120 V	1/2 Hp		9.8FLA/58.8 LRA
T6					
	Type of load	Voltage	Current	Temperature °C	—
	AC General Use	277 V	10 A (NC)	-40...+70	—

Model	T5				
	Type of load	Voltage	Current/Power	Temperature °C	Note
66.82.x.xxx.xxx3S	AC General Use	277 V	25 (NO)	-40...+40	—
	DC General Use	30 V	30 A	-40...+60	only 66.xx.9.x6x3
	AC Motor Starting, Discharge Lamps Break All lines	240 V	2 Hp	-40...+60	12FLA/69 LRA
		120 V	1 Hp		16FLA/96 LRA
		120 V	1/2 Hp		9.8FLA/58.8 LRA
T6					
	Type of load	Voltage	Current	Temperature °C	—
	AC General Use	277 V	10 A (NC)	-40...+70	—

HazLoc - Electrical characteristics

Contact specification HazLoc		HazLoc Class I Div. 2 T4 @ 60°C	HazLoc Class I Div. 2 T4 @ 70°C
Rated current/Maximum peak current	A	30/50 (NO) - 10/20 (NC)	25/50 (NO) - 10/20 (NC)
Rated voltage/Maximum switching voltage	V AC	250/400	250/400
Rated load AC1	VA	7500 (NO) - 2500 (NC)	6250 (NO) - 2500 (NC)
Rated load AC15	VA	1200 (NO)	1200 (NO)
Capacity for single phase motor (230 V AC)	kW	1.5 (NO)	1.5 (NO)
Breaking capacity DC1: 30/110/220 V	A	25/0.7/0.3 (NO)	25/0.7/0.3 (NO)
Characteristics of coil			
Rated voltage (U _N)	V AC (50/60 Hz)	6 - 12 - 24 - 110/115 - 120/125 - 230 - 240	
	V DC	6 - 12 - 24 - 110 - 125	
Rated Power AC/DC	VA (50 Hz)/W	3.6/1.7	
Operating range	AC/DC	(0.8...1.1)U _N	
General characteristics			
Ambient temperature	°C	-40...+70	

Outline drawings

Type 66.82-x003

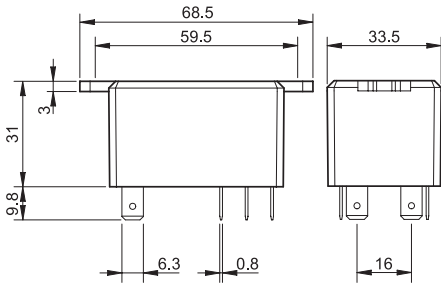

Type 66.82-x303/66.82-x603

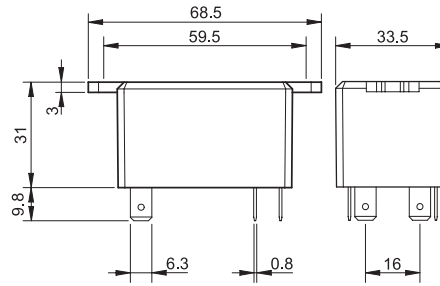

Type 66.22-xx03S/66.22-x603S

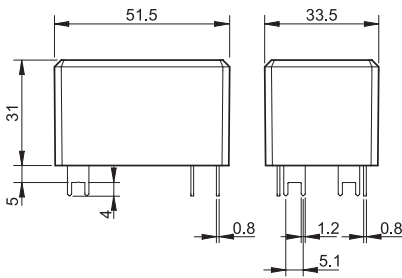

Accessories



066.07



066.07 with relay

Top 35 mm rail (EN 60715) mount for types 66.82.x.xxx.xxx3

066.07

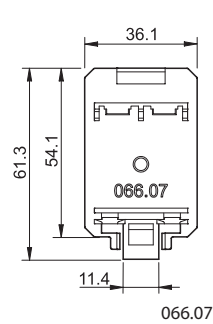

066.07

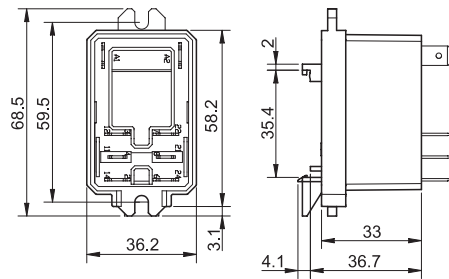

066.07 with relay

Modular timers 10 A IECEX - ATEX - HazLoc



Multi-function timer and IECEx - Ex - HazLoc multi-function modular timer

Type 83.02.0.240.0003

- Multi-function & multi-voltage IECEx, ATEX (Zone 2, Category 3), HazLoc (CI I, Div.2) timer
- 2 Pole (timed + instantaneous options), external time setting potentiometer option
- 22.5 mm wide
- Eight time scales from 0.05 s to 10 days
- High input/output isolation
- Wide supply range (24...240)V AC/DC
- 35 mm rail (EN 60715) mounting
- "Blade + cross" - both flat blade and cross head screw drivers can be used to adjust the range and function selectors, the timing trimmer, and to disengage the rail mounting clip
- Multi-voltage versions with "PWM clever" technology

83.02 - 0003



- IECEx - Ex - HazLoc
- Multi-voltage and Multi-function
- Timing can be adjusted using ext. Potentiometer
- 2 timed contacts or 1 timed + 1 instantaneous contact

- AI:** On-delay
- DI:** Interval
- GI:** Pulse delayed
- SW:** Symmetrical flasher (starting pulse on)
- BE:** Off-delay with control signal
- CE:** On- and off-delay with control signal
- DE:** Interval with control signal on
- WD:** Watchdog (Retriggerable interval with control signal on)

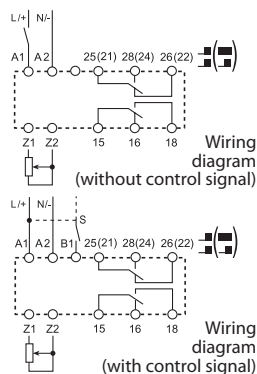

For outline drawing see page 56

Contact specification

Contact configuration		2 CO (DPDT)
Rated current/Maximum peak current	A	10/30
Rated voltage/ Maximum switching voltage	V AC	277/400
Rated load AC1	VA	2770
Rated load AC15 (230 V AC)	VA	750
Single phase motor rating (230 V AC)	kW	0.5
Breaking capacity DC1: 24/110/220 V	A	5/0.3/0.12
Minimum switching load	mW (V/mA)	300 (5/5)
Standard contact material		AgNi

Supply specification

Nominal voltage (U _N)	V AC (50/60 Hz)	24...240
	V DC	24...240
Rated power AC/DC	VA (50 Hz)/W	< 2/< 2
Operating range	V AC	16.8...265
	V DC	16.8...265

Technical data

Specified time range		(0.05...1)s, (0.5...10)s, (0.05...1)min, (0.5...10)min, (0.05...1)h, (0.5...10)h, (0.05...1)d, (0.5...10)d
Repeatability	%	± 1
Recovery time	ms	200
Minimum control impulse	ms	50
Setting accuracy-full range	%	± 5
Electrical life at rated load in AC1	cycles	60 · 10 ³
Ambient temperature range	°C	-20...+55
Protection category		IP 20

Approvals (according to type)



Ordering information

Example: 83 series, modular timers, 1 CO (SPDT) - 16 A, supply rated at (24...240)V AC/DC.

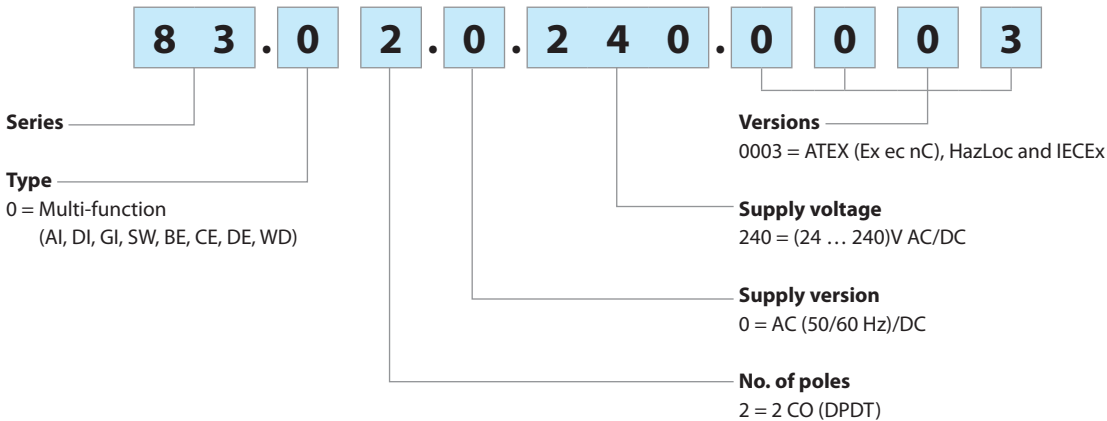

Technical data

Insulation				
Dielectric strength	between input and output circuit	V AC	4000	
	between open contacts	V AC	1000	
Insulation (1.2/50 µs) between input and output		kV	6	
EMC specifications				
Type of test	Reference standard			
Electrostatic discharge	contact discharge	EN 61000-4-2	4 kV	
	air discharge	EN 61000-4-2	8 kV	
Radio-frequency electromagnetic field	(80 ÷ 1000 MHz)	EN 61000-4-3	10 V/m	
	(1000 ÷ 2700 MHz)	EN 61000-4-3	3 V/m	
Fast transients (burst) (5-50 ns, 5 and 100 kHz)	on Supply terminals	EN 61000-4-4	7 kV	
	on control signal terminal (B1)	EN 61000-4-4	7 kV	
Surges (1.2/50 µs) on Supply terminals	common mode	EN 61000-4-5	6 kV	
	differential mode	EN 61000-4-5	6 kV	
	on control signal terminal (B1)	common mode	EN 61000-4-5	6 kV
	differential mode	EN 61000-4-5	4 kV	
Radio-frequency common mode on Supply terminals	(0.15 ÷ 80 MHz)	EN 61000-4-6	10 V	
	(80 ÷ 230 MHz)	EN 61000-4-6	10 V	
Radiated and conducted emission		EN 55022	class A	
Other data				
Current absorption on control signal (B1)		< 1 mA		
- max cable length (capacity of ≤ 10 nF/100 m)		150 m		
- when applying a control signal to B1, which is different from the supply voltage at A1/A2		B1 is isolated from A1 and A2 by an opto-coupler, and can therefore be operated at a voltage other than the supply voltage. If using a control signal of between (24...48)V DC and a supply voltage of (24...240)V AC, ensure that the signal - is connected to A2 and the + is applied to B1, and that L is applied to B1 and N to A2.		
External potentiometer		Use a 10 kΩ / ≥ 0.25 W linear potentiometer. Maximum cable length 10 m. When using an external potentiometer, the timer automatically use its setting in place of the internal setting. Consider the voltage potential at the potentiometer to be the same as the timer supply voltage.		
Power lost to the environment	without contact current	W	1.4	
	with rated current	W	3.2	
Screw torque		Nm	0.8	
Max. wire size	solid cable		stranded cable	
	mm ²	1 x 6 / 2 x 4	1 x 4 / 2 x 2.5	
	AWG	1 x 10 / 2 x 12	1 x 12 / 2 x 14	

Markings - ATEX, IECEx and HazLoc versions

ATEX (UL 23 ATEX 3005 X):	II 3 G	
IECEx (IECEx ULD 23.0013 X):	Ex ec nC IIC T4 Gc	
Haz.Loc. (E497395):	CI I, Div2, Gr A, B, C, D, T4 CI I, Zn 2, AEx ec nC IIC T4 Ex ec nC IIC T4 Gc X	
Specific marking of explosion protection		
II Component for surface plant (different from mines)		
3 Category 3: normal level of protection		
G - CI I Explosive atmosphere due to presence of combustible gas vapour or mist		
Div 2 - Zn 2 Hazardous explosive concentration presence just in case of fault		
Ex ec - AEx ec Increased safety		
Ex nC - AEx nC Sealed device		
IIC - Gr A, B, C, D Gas group		
T4 Temperature class		
Gc Device protection level		
-20°C ≤ Ta ≤ +55 °C Ambient temperature range		
UL 23 ATEX 3005 X - IECEx ULD 23.0013 X - E497395 UL - ULD: ID of the notified body which issues the type certificate 23: year of issue of the certificate 3005 - 0013: number of the type certificate E497395: UL file number X: special instruction for use		
Zyy: production batch identification Z: year, yy: week		



Outline drawings

Type 83.02
Box clamp

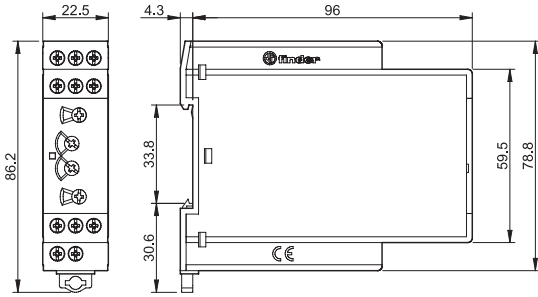

Functions

LED	Supply voltage	NO output contact	Contacts	
			Open	Closed
	OFF	Open	15 - 18 25 - 28	15 - 16 25 - 26
	ON	Open	15 - 18 25 - 28	15 - 16 25 - 26
	ON	Open (Timing in Progress)	15 - 18 25 - 28	15 - 16 25 - 26
	ON	Closed	15 - 16 25 - 26	15 - 18 25 - 28

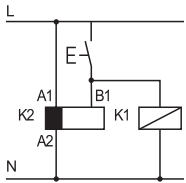

- Possible to control an external load, such as another relay coil or timer, connected to the control signal terminal B1.

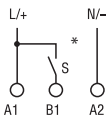

- * With DC supply, positive polarity has to be connected to B1 terminal (according to EN 60204-1).

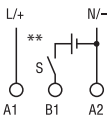

- ** A voltage other than the supply voltage can be applied to the control signal (B1), example:
A1 - A2 = 230 V AC
B1 - A2 = 12 V DC

Functions

Wiring diagram

Multi-function
without control signal

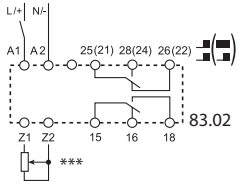

with control signal

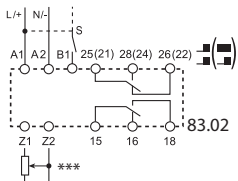

*** Type 83.02: regulated using an external potentiometer (10 kΩ - 0.25 W).

U = Supply voltage

S = Signal switch

= Output contact

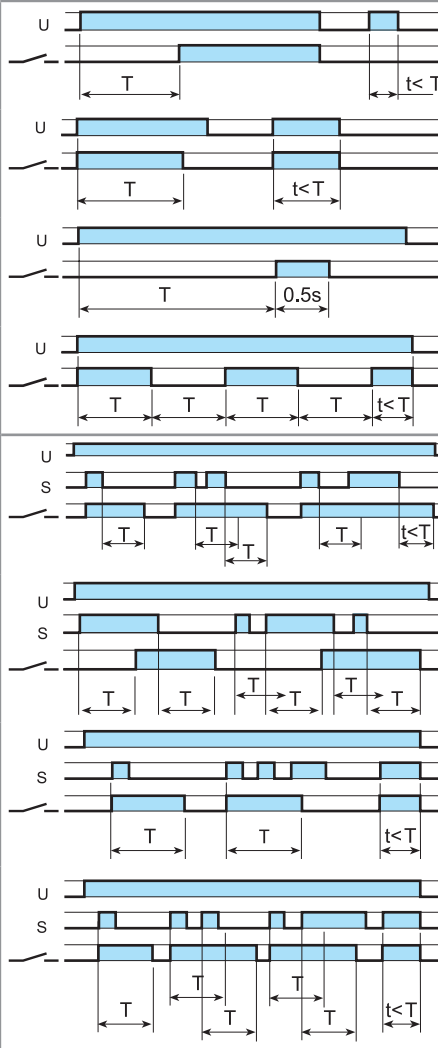

(AI) ON-delay.
Apply power to timer. Output contacts transfer after preset time has elapsed. Reset occurs when power is removed.

(DI) Interval.
Apply power to timer. Output contacts transfer immediately. After the preset time has elapsed, contacts reset.

(GI) Pulse delayed.
Apply power to timer. Output contacts transfer after preset time has elapsed. Reset occurs after a fixed time of 0.5s.

(SW) Symmetrical flasher (starting pulse ON).
Apply power to timer. Output contacts transfer immediately and cycle between ON and OFF for as long as power is applied. The ratio is 1:1 (time on = time off).

(BE) OFF-delay with control signal.
Power is permanently applied to the timer. The output contacts transfer immediately on closure of the control signal (S). Opening the control signal initiates the preset delay, after which time the output contacts reset.

(CE) ON- and OFF-delay with control signal.
Power is permanently applied to the timer. Closing the control signal (S) initiates the preset delay, after which time the output contacts transfer. Opening the control signal initiates the same preset delay, after which time the output contacts reset.

(DE) Interval with control signal ON.
Power is permanently applied to the timer. On momentary or maintained closure of control signal (S), the output contacts transfer, and remain so for the duration of the preset delay, after which they reset.

(WD) Watchdog (Retriggerable interval with control signal ON).
Power is permanently applied to the timer. On momentary or maintained closure of control signal (S), the output contacts transfer, and remain so for the duration of the preset delay, after which they reset; subsequent closures of control signal during the delay will extend the time. If the closure of the control signal (S) is longer than the preset time (T) then the output contacts reset.

NOTE: The timing function must be set when the timer is de-energised. Or for the 83.02, when the contact mode selector is in the OFF position.

Type 83.02

Contact mode selector	Functions without control signal (example: AI)	Functions with control signal (example: BE)
2 timed contacts 	 Both output contacts (15-18 and 25-28) follow the timing function	 Both output contacts (15-18 and 25-28) follow the timing function
OFF 	 Both output contacts [15-18 and 25(21)-28(24)] stay permanently open	 Both output contacts [15-18 and 25(21)-28(24)] stay permanently open
1 timed + 1 instantaneous contact 	 The output contact 15-18 follows the timing function The output contact 21-24 follows the power supply (U)	 The output contact 15-18 follows the timing function The output contact 21-24 follows the control signal (S)

Times scales

Rotary switch position 83 series

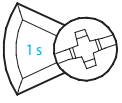

1 s
(0.05...1)s

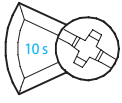

10 s
(0.5...10)s

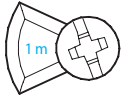

1 m
(0.05...1)min

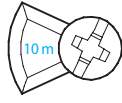

10 m
(0.5...10)min

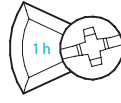

1 h
(0.05...1)h

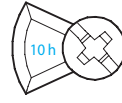

10 h
(0.5...10)h

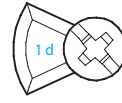

1 d
(0.05...1)d

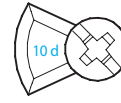

10 d
(0.5...10)d

Timer modules ATEX - HazLoc



Timer modules for use in conjunction with relay & socket

Type 86.30

- Bi-function & multi-voltage timer module
- ATEX compliant (Ex ec)
- HazLoc Class I Div. 2 Group A, B, C, D - T6
- Timer module type 86.30 for 94.0x.7 socket
- Wide supply voltage range:
12...24 V AC/DC
- LED indicator

86.30 - 0073



- Time scale: from 0.05 s to 100 h
- Bi-function
- Plug-in for use with 94.02.7, 94.03.7, 94.04.7 sockets

AI: On-delay
DI: Interval

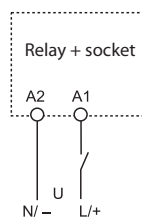

Wiring diagram

For outline drawing see page 63

Contact specification

Contact configuration	
Rated current/Maximum peak current	A
Rated voltage/Maximum switching voltage	V AC
Rated load AC1	VA
Rated load AC15 (230 V AC)	VA
Single phase motor rating (230 V AC)	kW
Breaking capacity DC1: 24/110/220 V	A
Minimum switching load	mW (V/mA)
Standard contact material	

See 58 series ATEX version

Supply specification

Nominal voltage (U _N)	V AC (50/60 Hz)	12...24
	V DC	12...24
Rated power AC/DC	W	0.15
Operating range	V AC (50/60 Hz)	9.6...33.6
	DC	9.6...33.6

Technical data

Specified time range		(0.05...1)s, (0.5...10)s, (5...100)s, (0.5...10)min, (5...100)min, (0.5...10)h, (5...100)h
Repeatability	%	± 1
Recovery time	ms	≤ 50
Setting accuracy full range	%	± 5
Electrical life at rated load in AC1	cycles	See 58 series ATEX version
Ambient temperature range	°C	-20...+50
Protection category		IP 20

Approvals (according to type)

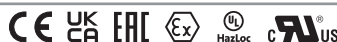

Ordering information

Example: 86 series Bi-function timer module, (12...24)V AC/DC supply voltage.

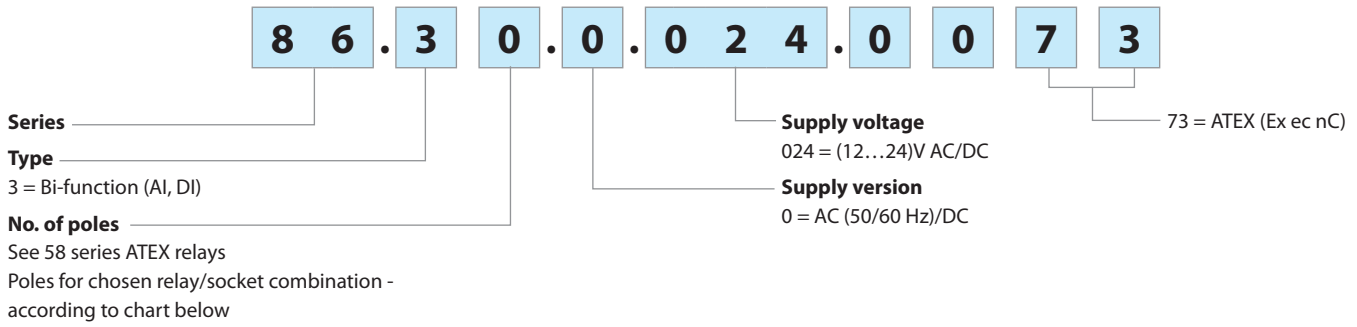

Supply range voltage ATEX certified

Code available	Nominal voltage	Operating range	Use temperature
86.30.0.024.0073	12-24 V AC/DC	9.6...33.6 V AC/DC	-20...+50°C

Markings - ATEX versions - ATEX, II 3G Ex ec IIC Gc

MARKING	
	Specific marking of explosion protection
II	Component for surface plant (different from mines)
3	Category 3: normal level of protection
GAS	G Explosive atmosphere due to presence of combustible gas vapour or mist
	Ex ec Increased security
	IIC Gas group
	Gc Equipment Protection Level
-20 °C ≤ Ta ≤ +50 °C Ambient temperature	
EPTI 17 ATEX 0264 U EPTI: laboratory which issues the CE type certificate 17: year of issue of certificate 0264: number of CE type certificate	
U: ATEX component	



86.30 timer module are designed to be used with 58 Ex relay interface only.
If used with other relays or standalone, the 86.30 cannot be considered Ex components anymore.

Technical data

EMC specifications

Type of test		Reference standard	
Electrostatic discharge	contact discharge	EN 61000-4-2	n.a.
	air discharge	EN 61000-4-2	8 kV
Radio-frequency electromagnetic field (80 ÷ 1000 MHz)		EN 61000-4-3	10 V/m
Fast transients (burst) (5-50 ns, 5 kHz) on Supply terminals		EN 61000-4-4	2 kV
Surges (1.2/50 µs) on Supply terminals	common mode	EN 61000-4-5	2 kV
	differential mode	EN 61000-4-5	1 kV
Radio-frequency common mode (0.15 ÷ 80 MHz) on Supply terminals		EN 61000-4-6	10 V
Radiated and conducted emission		EN 55022	class B

Other data

Current absorption on signal control (B1)		mA	—
Power lost to the environment	without contact current	W	0.2
	with rated current		See 58 series ATEX version

Times scales



NOTE: Time scales and functions must be set before energising the timer.

To achieve the minimum time setting of 0.05 seconds it is necessary to use one of the functions with control signal. When setting very short times it may be necessary to take into account the operate time of the relay used.

Outline drawings

Type 86.30

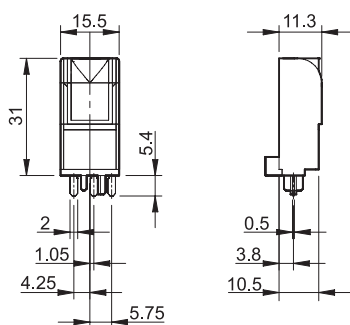

Functions

U = Supply voltage
S = Signal switch
 = Output contact

LED	Supply voltage	NO output contact
	OFF	Open
	ON	Open
	ON	Open (Timing in Progress)
	ON	Closed

Without control signal = Start via contact in supply line (A1).

Wiring diagram

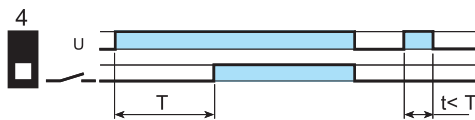
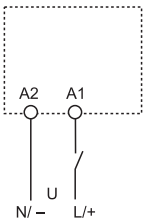

(AI) On-delay.

Apply power to timer. Output contacts transfer after preset time has elapsed. Reset occurs when power is removed.

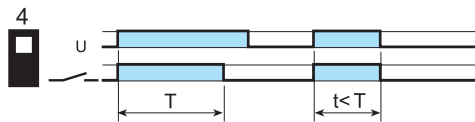

(DI) Interval.

Apply power to timer. Output contacts transfer immediately. After the preset time has elapsed, contacts reset.

 **FINDER SpA**
Via Drubiaglio 14
I-10040 ALMESE (TO)
Tel. +39 011 9346 211
Fax +39 011 9359 079
export@findernet.com

findernet.com



 **FINDER FRANCE Sarl**
306, Avenue d'Italie
ZI du Pré de la Garde
73300 ST. JEAN DE MAURIENNE
Tel.+33/479/83 27 27
Fax +33/479/59 80 04
finder.fr@findernet.fr

 **S.R.L FINDER BELGIUM - B.V.**
Bloemendael, 5
B - 1547 BEVER
Tel. +32/54/30 08 68
finder.be@findernet.com

 **FINDER plc**
Opal Way, Stone Business Park,
Stone, Staffordshire,
ST15 0SS - UK
Tel: +44 (0)1785 818100
enquiries.uk@findernet.com

 **FINDER AB**
Sångleksgatan 6c
SE - 215 79 Malmö
Tel: +46 (0) 40 93 77 77
Fax:+46 (0) 40 93 78 78
finder.se@findernet.com

 **FINDER ApS**
Bøstrupvej 11
DK-8870 Langå
Tel. +45 69 15 02 10
Fax +45 69 15 02 11
finder.dk@findernet.com

 **FINDER COMPONENTES LTDA.**
Rua Olavo Bilac, 326
Bairro Santo Antônio
São Caetano Do Sul - São Paulo
CEP 09530 - 260 - BRASIL
Tel. +55 11 4223 1550
Tel. +55 11 2147 1550
Fax +55 11 4223 1590
finder.br@findernet.com

 **FINDER ARGENTINA S.R.L.**
Calle Martín Lezica 3079
San Isidro - Buenos Aires
CP B1642GJA - ARGENTINA
Tel +54 11 7535.8500
Fax +54 11 7535.5444
finder.ar@findernet.com

 **FINDER LATAM S.A.**
Logistic Center for South America
Ruta 8 km 17.500 – Edificio Quantum – Of: 504
CP: 91600 – Zonamerica – Montevideo – UY
finder.latam@findernet.com

 **FINDER TURKEY ELEKTRIK A.Ş.**
İçerenköy Mah. Bahçelerarası Sok. Mete
Plaza No:43 Kat:15 34752
Ataşehir/İstanbul/Türkiye
Tel: +90 216 575 15 13
finder.tr@findernet.com

 **FINDER GmbH**
Hans-Böckler-Straße 44
D - 65468 Trebur-Astheim
Tel. +49 6147 2033-0
Fax +49 6147 2033-377
info@finder.de

 **FINDER RELAIS NEDERLAND B.V.**
Dukdalfweg 51
1041 BC AMSTERDAM - NEDERLAND
Tel. +31/20/615 65 57
Fax +31/20/617 89 92
finder.nl@findernet.com

 **FINDER RELAIS VERTRIEBS GmbH**
IZ NÖ-Süd, Str. 2a, Obj. M 40
A - 2351 Wiener Neudorf
Tel. +43/2236/86 41 36 - 0
Fax +43/2236/86 41 36 - 36
finder.at@findernet.com

 **FINDER CZ, s.r.o.**
Radiová 1567/2b
CZ - 102 00 PRAHA 10
Tel. +420 286 889 504
Fax +420 286 889 505
finder.cz@findernet.com

 **FINDER - Hungary Kereskedelmi Kft.**
Kiss Ernő u. 3/A.
HU - 1046 BUDAPEST
Tel. +36/1-369-30-54
Fax +36/1-369-34-54
finder.hu@findernet.com

 **FINDER d.o.o.**
Peske 17
1236 Trzin, Slovenija
Tel. +386 (0)1 561 5981
sales.si@findernet.com

 **FINDER (Schweiz) AG**
Industriestrasse 1a
CH - 8157 DIELSDORF (ZH)
Tel. +41 44 885 30 10
Fax +41 44 885 30 20
finder.ch@finder-relais.ch

 **FINDER ELECTRICA S.L.U.**
C/ Severo Ochoa, 6
Pol. Ind. Cap de L'Horta
E - 46185 La Pobla de Vallbona (VALENCIA)
Apdo Postal 234
Telf. Oficina Comercial 93 836 51 30
finder.es@findernet.com

 **FINDER PORTUGAL LDA**
Travessa Campo da Telheira, n. 56
Vila Nova da Telha,
P - 4470-828 - MAIA
Tel. +351 22 99 42 900
Tlm. +351 910 935 798
finder.pt@findernet.com

 **FINDER ECHIPAMENTE srl**
Str. Clujului nr. 75 F,
401180 Turda
Jud. CLUJ - ROMANIA
Tel. +40 264 403 888
finder.ro@finder.ro

 **FINDER OOO**
Bakuninskaya street, 78/1
105082 MOSCOW
RUSSIAN FEDERATION
Tel. +7/495/229-49-29
Fax +7/495/229-49-42
finder.ru@findernet.com

 **FINDER BALTIC, UAB**
Eiguliu str. 9-1
Vilnius, LT-03150
Lithuania
Tel. +370 526 53 027
finder.lt@findernet.com

 **FINDER Polska Sp. z o.o.**
ul. Logistyczna 27
62-080 Sady
Tel. +48 61 865 94 07
Fax +48 61 865 94 26
finder.pl@findernet.com

 **FINDER COMPONENTS INC.**
5028 South Service Road
Burlington, ONTARIO L7L 5Y7
Toll Free 1 800 265 6263
Local 905 681 7767
finder.ca@findernet.com

 **FINDER RELAYS, INC.**
4191 Capital View Drive
Suwanee, GA 30024 - U.S.A.
Tel. +1/770/271-4431
finder.us@findernet.com

 **RELEVADORES FINDER, S.A. de C.V**
Carretera a San Bernardino Chalchihuapan #43
San Pablo Ahuatempan, Santa Isabel Cholula, Puebla.
C.P. 74350 - MÉXICO.
Tel. +52/222/2832392, 2832393, 2832394
Fax. +52/222/7628471
finder.mx@findernet.com

 **FINDER Panamá S.A.**
Tel. +507 6873-4887
finder.pa@findernet.com

 **FINDER ASIA Ltd.**
Room 901 - 903, 9F, Premier
Center20 Cheung Shun Street
Cheung Sha Wan, Kowloon
Hong Kong
Tel. +852 3188 0212
Fax +852 3188 0263
finder.hk@findernet.com

 **FINDER INDIA PVT. LTD.**
C-94, Lower Ground,
Upper ground, First floor,
Mangolpuri Industrial Area,
Phase -1, New Delhi - 110083, INDIA
Tel. +91-11-47564343
Fax +91-11-47564344
finder.in@findernet.com

Finder reserves the right to make changes to its products and their technical specifications at any time and without prior notice, as part of its policy of continuous improvement. The information contained in this document is provided for indicative purposes only and does not constitute a contractual obligation; errors and omissions excepted. In the event of any discrepancy between the printed and online versions, the latter, available at findernet.com, shall prevail.