



Industrial Ethernet Switches

Reference Guide



Table of Contents

Industrial Unmanaged Switches	3
Unmanaged Power Over ETHERNET (PoE+)	4
Industrial Unmanaged Switches	5
Lean Managed Switches	6
MACsec Managed Switches.	8
Industrial Managed PROFINET Switches	10
Industrial Managed Switches	12
Function Overview of the Industrial Managed Switch.	13
Availability	14
Security.	15
Data Transmission	16
Performance.	17
Administration and Diagnostics.	18
Quick Reference Guide	19
RJ45 Connectors	20
RJ45 Interface Modules	21
SFP Modules	22
RJ45 Cords	23
WAGO Protect	24
Bulkhead Sockets	25
Wireless ETHERNET Gateway.	26
Industrial Gigabit PoE Injector	28
Industrial Media Converts	29
Switches Selection Guide	30

Compact housing

- Only 1 inch wide

Power supply

- Pluggable connector
- CAGE CLAMP®, vibration-resistant and maintenance-free connections
- Wide operating voltage

Five ETHERNET ports

- Auto-negotiation 10/100/1000 Mbit/s
- Auto-MDI/MDI-X crossover
- Status LEDs: link/output/activity

Robust design

- DIN rail mounting and metal housing
- Excellent vibration and shock resistance
- Wide operating temperature

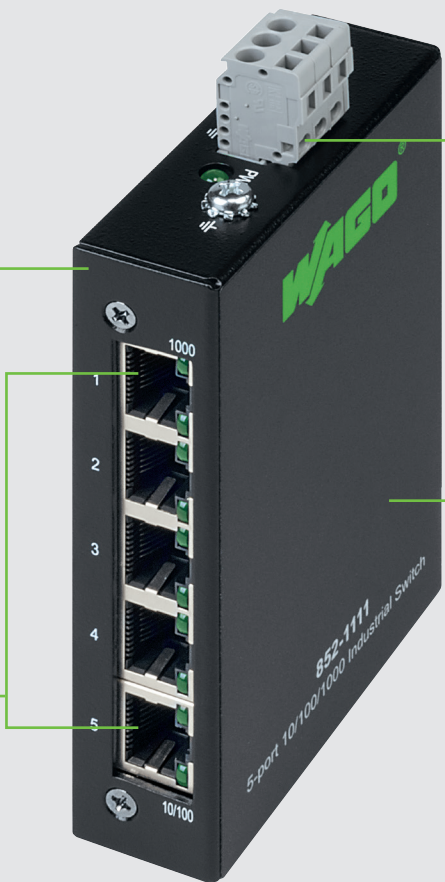

Industrial Unmanaged Switches

Eco – Economical and Compact

	Unmanaged			Fast ETHERNET		Gigabit	
Ports	5 x 10/100	8 x 10/100	8 x 10/100	5 x 10/100/1000	8 x 10/100/1000	5 x 10/100/1000	8 x 10/100/1000
Power Supply	18 ... 30 VDC	18 ... 30 VDC	12 ... 48 VDC	12 ... 48 VDC	12 ... 48 VDC	12 ... 48 VDC	12 ... 48 VDC
Dimensions (W x H x D)	23.4 x 109.2 x 73.8 mm 0.92 x 4.3 x 2.9 in	109.2 x 73.8 x 23.4 mm 4.3 x 2.9 x 0.92 in	46 x 116 x 99.6mm 1.8 x 4.6 x 3.9 in	23.4 x 109.2 x 73.8 mm 0.92 x 4.3 x 2.9 in	46 x 116 x 99.6 mm 1.8 x 4.6 x 3.9 in	23.4 x 109.2 x 73.8 mm 0.92 x 4.3 x 2.9 in	46 x 116 x 99.6 mm 1.8 x 4.6 x 3.9 in
Temperature	-40 ... +70 °C -40 ... +158 °F	-40 ... +70 °C -40 ... +158 °F	-40 ... +70 °C -40 ... +158 °F	-40 ... +70 °C -40 ... +158 °F	-40 ... +70 °C -40 ... +158 °F	-40 ... +70 °C -40 ... +158 °F	0 ... +60 °C +32 ... +140 °F
Approvals	cULus	cULus	cULus	cULus	cULus	cULus	cULus
PROFINET	-	-	CC-A	CC-A	CC-A	CC-A	CC-A
Part Number	852-111/000-001	852-112	852-112/000-001	852-111/000-001	852-112/000-001	852-111/000-001	852-112/000-001

¹ With DIN 852-9101 rail adapter

Power supply

- Pluggable connector
- Vibration-proof, maintenance-free power supply connection
- Wide operating voltage

5 RJ45 ports 1 Gb/s

- 4 ports PoE+ (30 W)
- 1 Uplink port

Fiber-optic version

- 2 SFP* ports



Status LEDs

- Power supply is connected
- PoE sensor is powered
- Communication partner is connected
- Data is being transmitted

Operating temperature:
-40 ... +158 °F

* Small form-factor pluggable interface for fiber-optic cables

Unmanaged Power over ETHERNET (PoE+)

Unmanaged		
PoE+ Ports	4 x PoE+ (30 W)	4 x PoE+ (30 W)
Copper Ports	5 x 10/100/1000	5 x 10/100/1000
SFP Ports	2 x SFP 1000	-
Power Supply	24 ... 57 VDC	24 ... 57 VDC
Dimensions (W x H x D)	50 x 120 x 160 mm 1.9 x 4.7 x 6.3 in	50 x 115 x 100 mm 1.9 x 4.5 x 3.9 in
Temperature	-40 ... +70 °C -40 ... +158 °F	-20 ... +60 °C -4 ... +140 °F
Approvals	cULus	cULus ¹
Part Number	852-1417	852-1411/0000-0001

"Power over ETHERNET" (PoE+) technology powers PoE-capable devices via network cable using a switch. This allows devices like PoE-capable IP cameras or IoT sensors to be economically integrated into the network, eliminating the separate installation of power and data cables. Other advantages include diagnostics performed within the system.

The IEEE 802.3at-2009 PoE standard, which is also known as PoE+ or PoE plus standard, provides up to 25.5 W of power to the PoE-capable devices. To make this possible, the PoE-capable switch can provide up to 30 W per PoE-enabled port.

¹ For supply voltage <48 VDC, the PoE budget is limited to 60 watts



Power supply

- Redundant power supply terminals
- Wide voltage range
- Pluggable connector

Robust design

- DIN rail mounting and metal housing
- Excellent vibration and shock resistance
- Temperature range: -40 ... +158 °F

Alarm contact





- Monitor power supplies
- ETHERNET port monitoring
- Signaling via PLC or remote I/O
- Indicator LEDs on front panel of cabinet

Configuration via DIP switches



Industrial Unmanaged Switches

Standard – Versatile Use

Unmanaged	Fast ETHERNET			Gigabit	
					
Copper Ports	5 x 10/100	8 x 10/100	8 x 10/100	8 x 10/100/1000	16 x 10/100/1000
Fiber-Optic Ports	-	-	2 x SFP 100*	-	-
Power Supply	9 ... 48 VDC	9 ... 48 VDC	9 ... 48 VDC	9 ... 57 VDC	12 ... 60 VDC
Redundant Power Supply	Yes	Yes	Yes	Yes	Yes
Alarm Contact	Yes	Yes	Yes	Yes	Yes
Dimensions (W x H x D)	50 x 120 x 105 mm 2 x 4.7 x 4.1 in	50 x 162 x 105 mm 2 x 6.4 x 4.1 in	50 x 162 x 105 mm 2 x 6.4 x 4.1 in	50 x 120 x 105 mm 2 x 4.7 x 4.1 in	50 x 162 x 120 mm 2 x 6.4 x 4.72 in
Temperature	-40 ... +70 °C -40 ... +158 °F	-40 ... +70 °C -40 ... +158 °F	-40 ... +70 °C -40 ... +158 °F	-40 ... +70 °C -40 ... +158 °F	-10 ... +70 °C 14 ... +158 °F
Approvals	cULus	cULus	cULus	cULus	cULus, DNVGL, LR
PROFINET	-	-	-	CC-A ¹	CC-A ¹
Part Number	852-101	852-102	852-103	852-1102	852-1106

¹ No PROFINET configuration and diagnostics with conformity class A

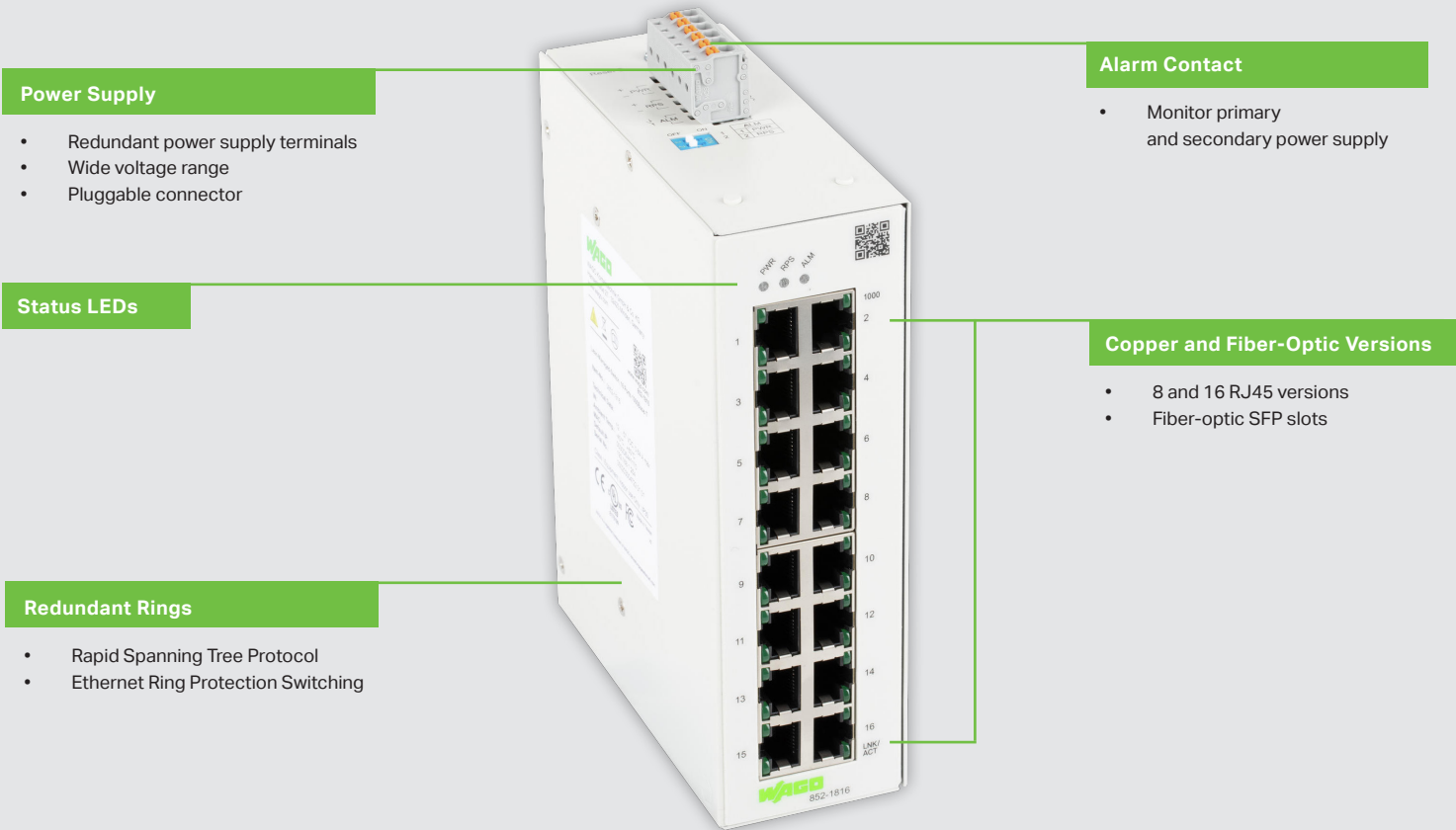

Power Supply

- Redundant power supply terminals
- Wide voltage range
- Pluggable connector

Alarm Contact

- Monitor primary and secondary power supply

Status LEDs

Copper and Fiber-Optic Versions

- 8 and 16 RJ45 versions
- Fiber-optic SFP slots

Redundant Rings

- Rapid Spanning Tree Protocol
- Ethernet Ring Protection Switching

Lean Managed Switches

Economical Managed Switches Optimized for Industrial Networking

Lean Managed



Copper Ports	8 x 10/100/1000	8 x 10/100/1000	8 x 10/100/1000	16 x 10/100/1000
PoE+ Ports	-	-	8 (up to 240 W)	-
SFP Ports	-	2 x 100 or 1000	2 x 100 or 1000	-
Redundant Power Supply	Yes	Yes	Yes	Yes
Power Supply	24 ... 28 VDC	24 ... 48 VDC	24 ... 57 VDC	12 ... 60 VDC
Alarm Contact	Yes	Yes	Yes	Yes
Dimensions (W x H x D)	50 x 116 x 100 mm 2 x 4.5 x 3.9 in	50 x 116 x 100 mm 2 x 4.5 x 3.9 in	50 x 120 x 160 mm 2 x 4.7 x 6.3 in	50 x 120 x 160 mm 2 x 4.7 x 6.3 in
Temperature	-10 ... +60 °C 14 ... +140 °F	-10 ... +60 °C 14 ... +140 °F	-10 ... +60 °C 14 ... +140 °F	-40 ... +60 °C -40 ... +140 °F
Approvals	CE, cULus	CE, cULus	CE, cULus	CE, cULus
Topology Map/Dashboard	Yes	Yes	Yes	Yes
Part Number	852-1812/010-000	852-1813/010-000	852-1813/000-001	852-1816

Lean Managed Switches

Lean Managed Switches are engineered for use in industrial environments that are installed and maintained by control minded Automation Engineers and Technicians. Unique tools such as a graphical active topology map and diagnostic dashboards provide users information to easily monitor and troubleshoot any industrial network. WAGO's Lean Managed Switches offer network tools that Control Engineers need without the overhead of IT related features that are commonly not used on the plant floor.

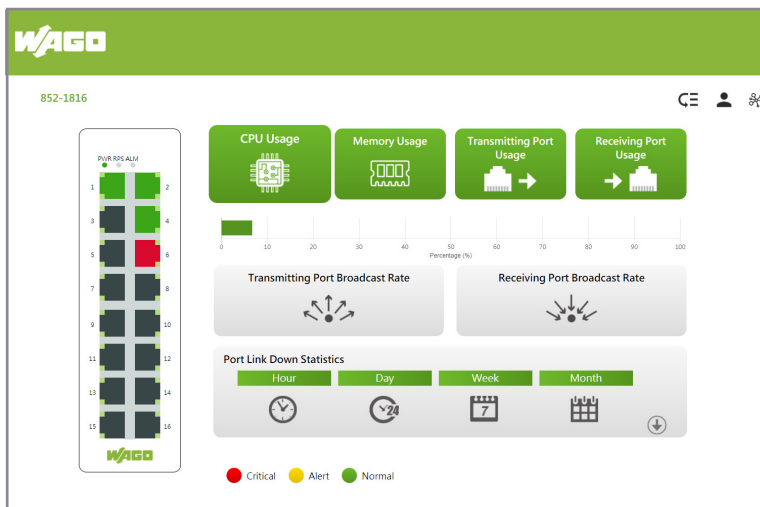

Web-based Dashboard Network Health at a Glance

- Red, yellow and green indicators for instant network health status
- Port link status for all used ports
- Transmission TX and RX usage
- Port broadcast rates

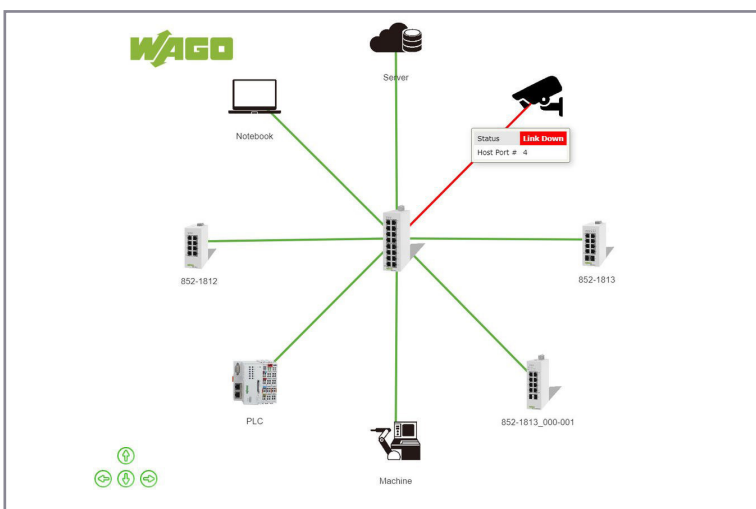

Web-based Topology Map Network Status View

- Network connectivity information
- Connection status via green/red visualization
- Link information

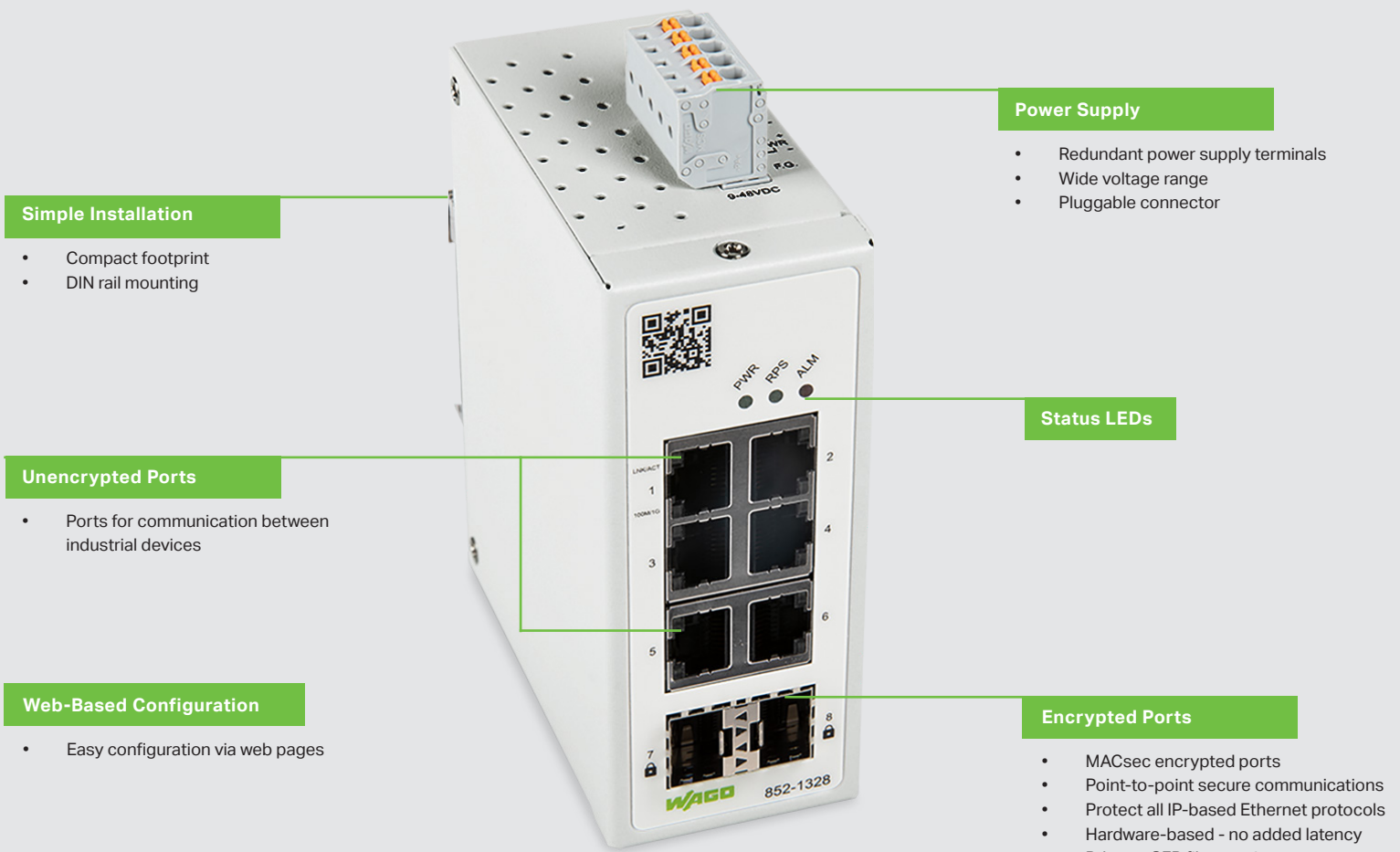

Simple Installation

- Compact footprint
- DIN rail mounting

Power Supply

- Redundant power supply terminals
- Wide voltage range
- Pluggable connector

Unencrypted Ports

- Ports for communication between industrial devices

Status LEDs

Web-Based Configuration



- Easy configuration via web pages

Encrypted Ports

- MACsec encrypted ports
- Point-to-point secure communications
- Protect all IP-based Ethernet protocols
- Hardware-based - no added latency
- RJ45 or SFP fiber-optic ports

MACsec Encrypted Managed Switches

Encrypt Fieldbus Networks for Enhanced Cybersecurity

	Gigabit	
		
Copper Ports	8 x 10/100/1000	6 x 10/100/1000
with MACsec	2 x RJ45	2 x SFP
Ports Fiber	None	2 x SFP 100/1000
Alarm Redundancy	Yes	Yes
Dimensions (W x L x H)	45.3 x 92 x 110 mm 1.7 x 3.6 x 4.3 in	45.3 x 92 x 110 mm 1.7 x 3.6 x 4.3 in
Temperature	-20 ... +70 °C -4 ... +158 °F	-20 ... +70 °C -4 ... +158 °F
Power Supply	9 ... 48 VDC	9 ... 48 VDC
Approvals	CE, cULus	CE, cULus
Part Number	852-1322	852-1328

Help increase cybersecurity on the plant floor using easy to implement Media Access Control Security or MACsec technology. (IEEE 802.1AE)

Whether for new applications or retrofitting, MACsec managed switches will encrypt fieldbus such as MODBUS, Ethernet/IP, BACnet, and Profinet or IIoT protocols including HTTP, or MQTT. Install communication encryption without modifying your applications.

MACsec Data Encryption

MACsec Encryption

- IEEE 802.1 AE standard
- Encrypt IP-based protocols such as HTTP, MQTT, MODBUS TCP, BACnet, PROFINET, or EtherNet/IP
- No latency encryption - hardware based
- Secure against multiple threats:
 - Man-in-the-middle
 - Masquerading
 - Passive wiretapping
 - Playback attacks

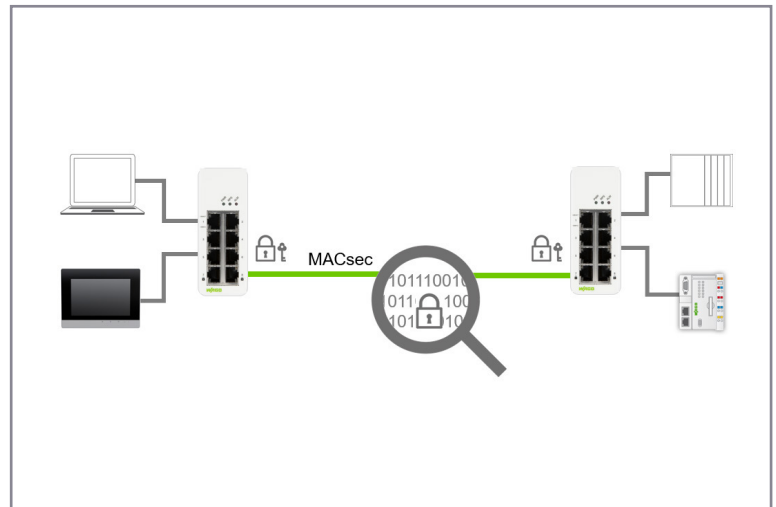

Green or Brown Field

- Easy to retrofit in a network - use existing Ethernet cables
- Use within a plant for horizontal security
- Use between manufacturing buildings
- Space-saving control cabinet installation

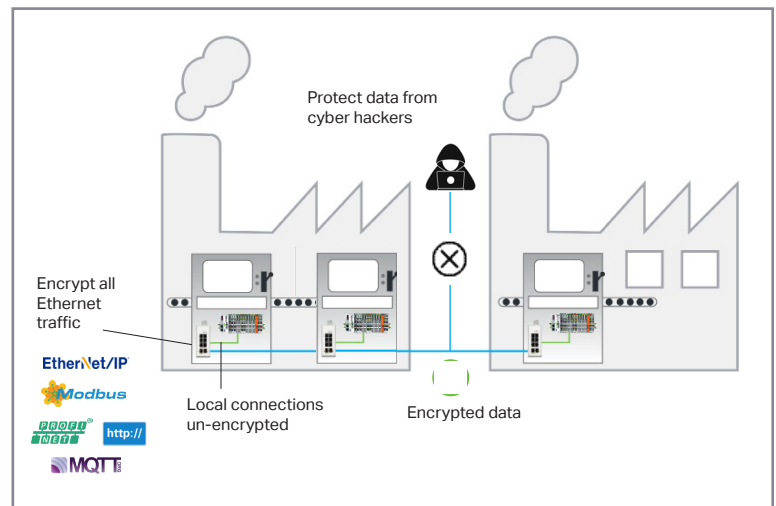

Redundant power supply

Alarm contact

- Monitors the primary and secondary power supply
- Monitors ETHERNET ports
- Signals via PLC or remote I/Os

Switch configuration through the PROFINET Configurator (GSD)

Potential-free connection via SFP modules: cable lengths up to 80 km

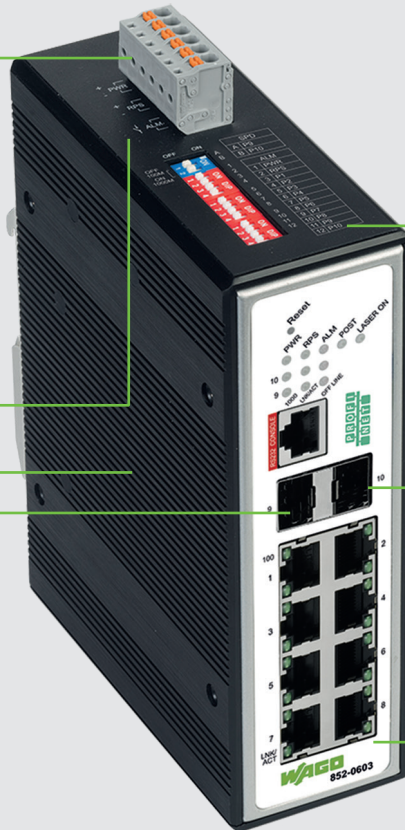

PROFINET diagnostics from the application: cyclically readable process image

Flexible port mirroring configuration: via GSDML or Web-Based Management

Integrated Web-Based Management for configuration or diagnostics

* Small form-factor pluggable interface for fiber-optic cables

Industrial Managed PROFINET Switches

Performance, Availability, Data Transmission & Security

Managed			
			
Copper ports	8 x 10/100BASE-TX	8 x 10/100BASE-TX	8 x 10/100/1000BASE-T
SFP ports		2 x SFP 100/1000 ²	4 x SFP 1000BASE-SX/LX
Supply voltage	12 ... 60 VDC	12 ... 60 VDC	12 ... 60 VDC
Redundant power supply	Yes	Yes	Yes
Alarm contact	Yes	Yes	Yes
Dimensions (W x H x D)	50 x 162 x 122 mm 2 x 6.4 x 4.8 in	50 x 162 x 122 mm 2 x 6.4 x 4.8 in	50 x 162 x 122 mm 2 x 6.4 x 4.8 in
Surrounding air temperature (operation)	-40 ... +70 °C -40 ... +158 °F	-40 ... 70 °C -40 ... +158 °F	-40 ... 70 °C -40 ... +158 °F
Approvals	cULus	cULus	cULus
PROFINET	CC-B	CC-B	CC-B
Item number	852-602	852-603	852-1605

Suitable SFP modules on page 17

² Configurable via DIP switches (1000BASE-SX/LX or 100BASE-FX)

PROFINET-Specific Features

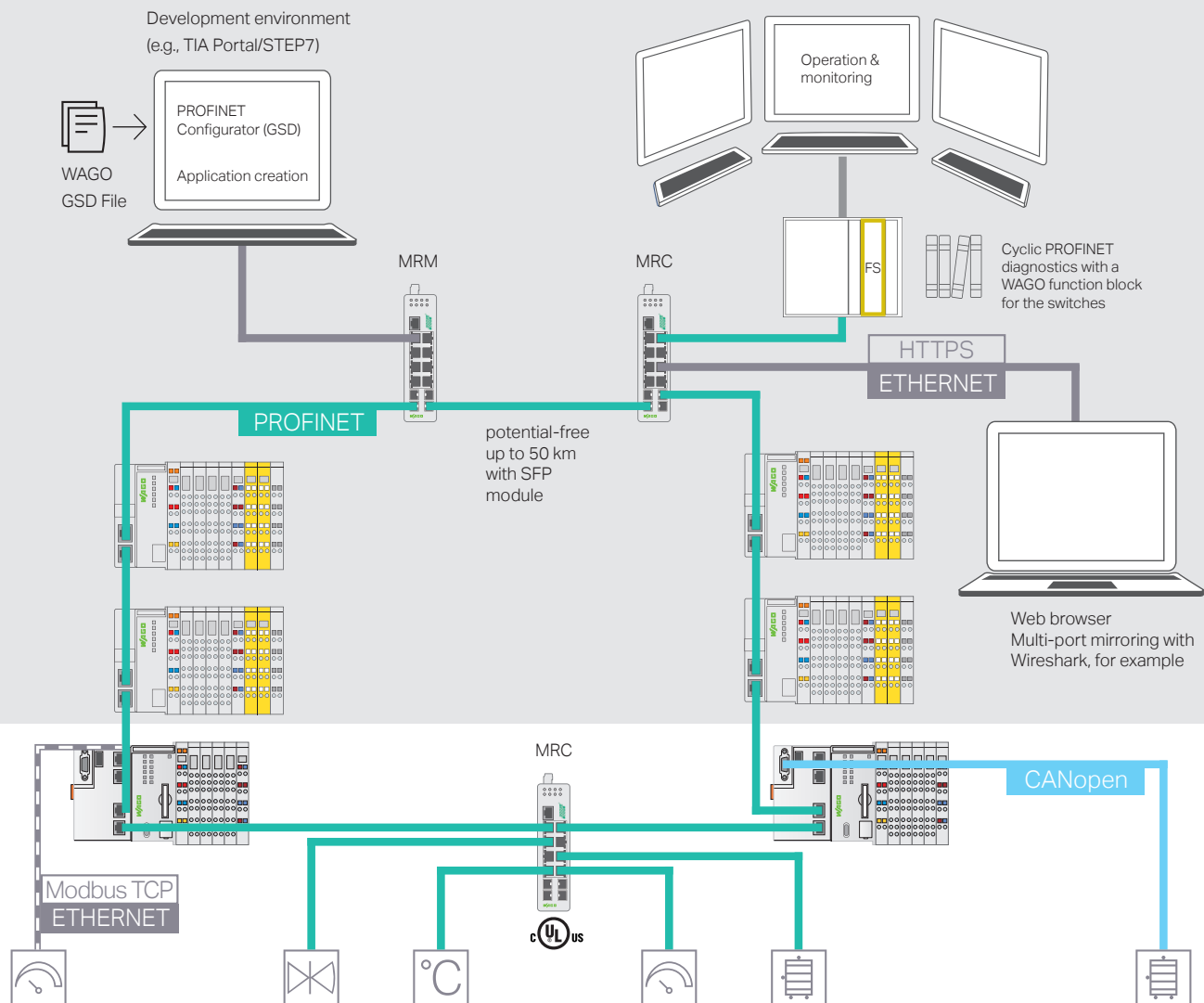

The following products meet the requirements of PROFINET conformity class A (CC-A):
 852-1111, 852-1112, 852-1411,
 852-1411/000-001 and 852-1417

Special Product Features:

- Prioritized PROFINET data packet forwarding
- Configuration via GSDML file not possible
- Neighborhood detection and PROFINET diagnostics not supported

Your Benefits:

- Use in industrial automation thanks to PROFINET certificate (conformity class B)
- Port-independent configuration of the media redundancy protocol as a manager (MRM) or client (MRC)
- Flexible multi-port mirroring configuration via device description file
- Switch configuration with device description file

Power supply

- Redundant power supply terminals
- Wide voltage range
- Pluggable connector

Alarm contact

- Monitor power supply
- ETHERNET port monitoring
- Signaling via PLC or remote I/O

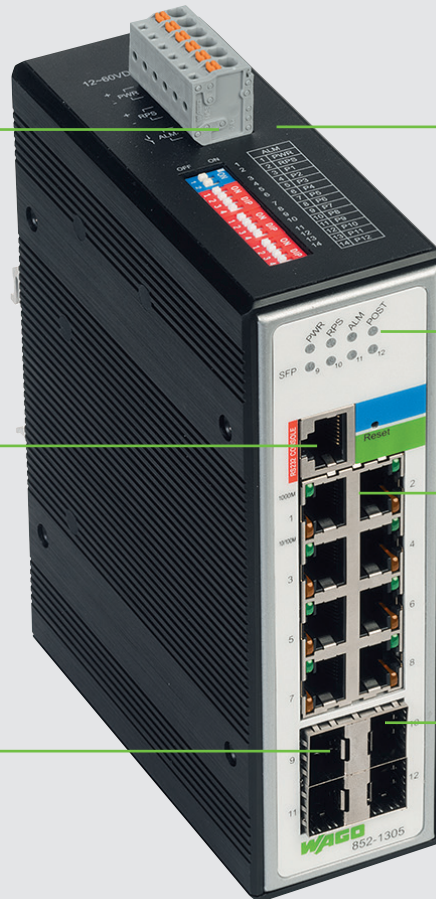

Status LEDs

RS-232 maintenance interface

RJ45 ports

Location for fiber-optic SFP modules*

Network security features**





- Authentication
- Firewall
- Port security

* Small form-factor pluggable

** See page 13 for more details

Industrial Managed ETHERNET Switches

Performance, Availability, Data Transmission & Security

Managed				PoE+
				
PoE+ Ports				8 x PoE+ (30 W)
Copper Ports	8 x 10/100	8 x 10/100/1000	8 x 10/100/1000	8 x 10/100/1000
Fiber-Optic Ports	2 x SFP 100/1000 ¹	4 x SFP 1000	4 x SFP 1000	4 x SFP 1000
Power Supply	12 ... 60 VDC	12 ... 60 VDC	12 ... 48 VDC	24 ... 57 VDC
Redundant Power Supply	Yes	Yes	Yes	Yes
Alarm Contact	Yes	Yes	Yes	Yes
Dimensions (W x H x D)	50 x 162 x 120 mm 2 x 6.4 x 4.7 in	50 x 162 x 120 mm 2 x 6.4 x 4.7 in	50 x 162 x 120 mm 2 x 6.4 x 4.7 in	50 x 162 x 120 mm 2 x 6.4 x 4.7 in
Temperature	-40 ... +70 °C -40 ... +158 °F	-40 ... +70 °C -40 ... +158 °F	-40 ... +70 °C -40 ... +158 °F	-40 ... +70 °C -40 ... +158 °F
Approvals	cULus, DNV	cULus, DNV	cULus, IEC 61850-3	cULus, IEC 61850-3
PROFINET	CC-A	CC-A		
Part Number	852-303	852-1305	852-1305/000-001	852-1505/000-001²

¹ Configurable via DIP switches (1000BASE-SX/LX or 100BASE-FX)

² For supply voltage < 48 VDC, the PoE budget is limited to 120 watts

* Suitable SFP modules on page 17

Function Overview of the Industrial Managed Switch

- Storm Control
- Bandwidth Control
- Auto-Provisioning
- Link Aggregation

- ERPS
- Dual Homing²
- Xpress/Jet Ring²
- Dual Ring²
- STP/RSTP
- MRM/MRC^{1,2}

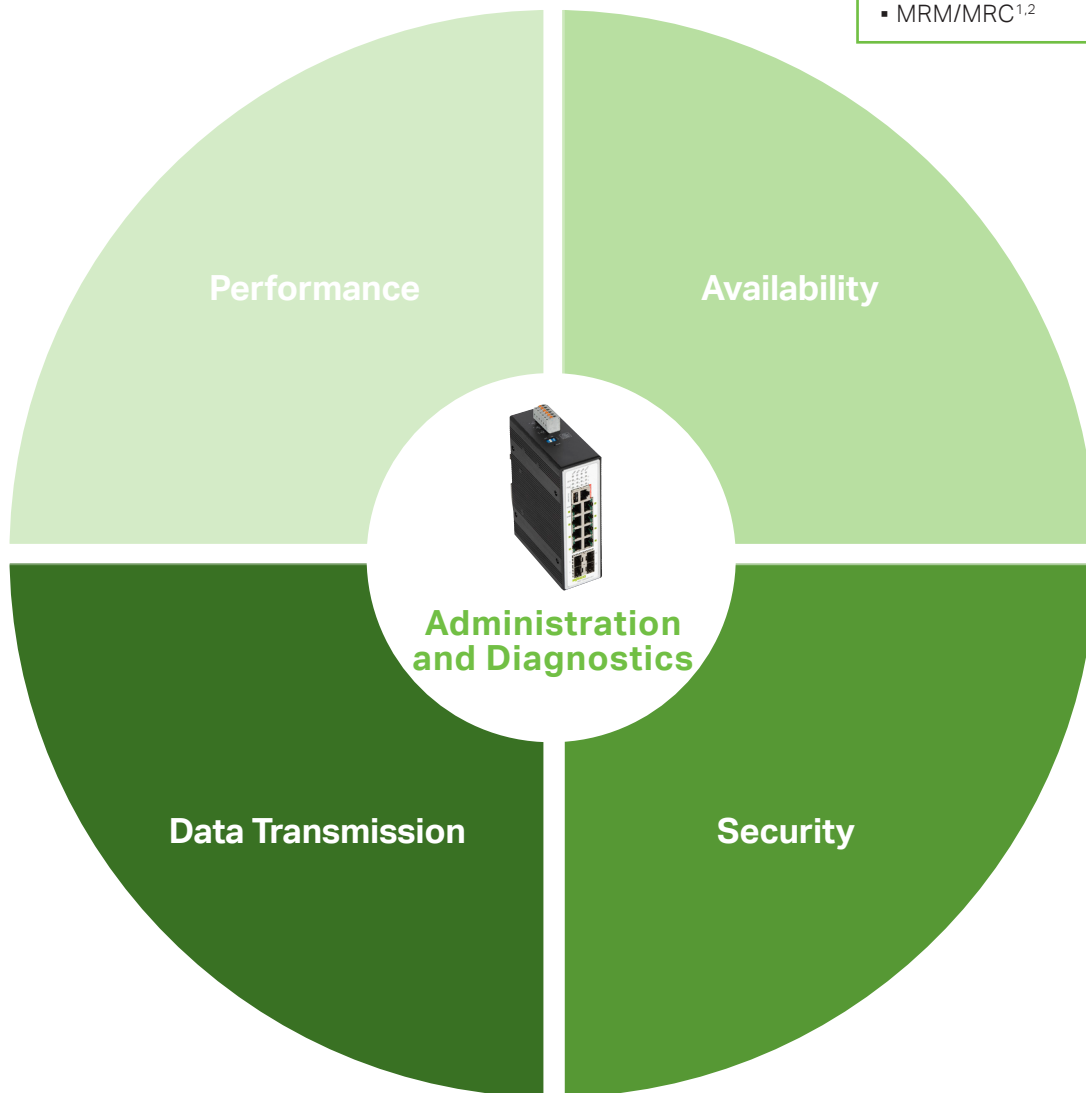

- VLAN
- IGMP Snooping
- IP-based VLAN²
- MAC-based VLAN²

- IEEE 802.1X Authentication
- Firewall
- DHCP Snooping²
- Port Security
- Service Control

¹ Only available in 852-602, 852-603 and 852-1605.

² Not available in lean managed switches.

Availability

via Communication Redundancy

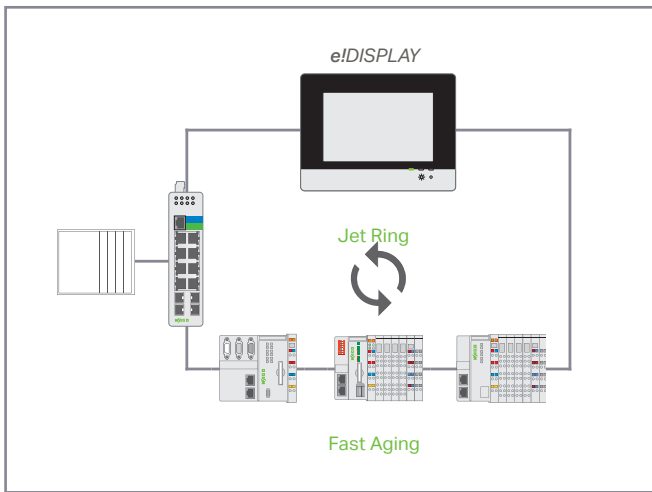

Jet Ring

Jet Ring¹

Fast, Easy Setup Ring Topology

- Typical switching time of 400 ms (depends on the application)
- Extremely easy configuration (on or off)
- Up to 20 switches in a Jet Ring
- WAGO ETHERNET devices (Fast Aging) can be used in the Jet Ring

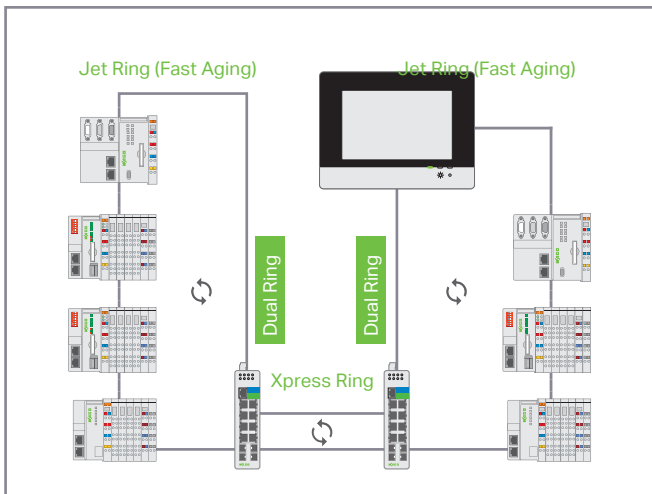

Xpress Ring and Dual Ring

Xpress Ring¹

High Speed Reconfiguration

- Switching time < 20 ms
- Easy configuration (three parameters per switch)
- Up to 200 switches in one Xpress Ring
- Two Xpress Rings per switch

Dual Ring¹

- Combination of both redundancy types
- 1 Jet Ring and 1 Xpress Ring per switch or 2 Xpress Rings per switch

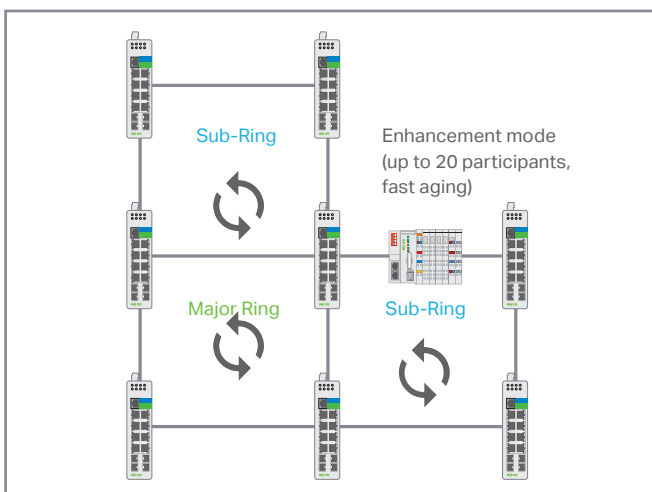

ERPS V2

ERPS: ETHERNET Ring Protection Switching

The Fast and Open Solution

- Standardized and open technology
- Switching time < 800 ms
- Nested topologies
- Realization of one-fault tolerance (SPOF – Single Point of Failure)

ERPS – Enhancement Mode¹

- WAGO devices with an integrated switch and Fast Aging configuration
- Typical switching time of 400 ms (depends on the application)

¹ Not available in lean managed switches.

Security

Absolutely Secure Industrial Networks

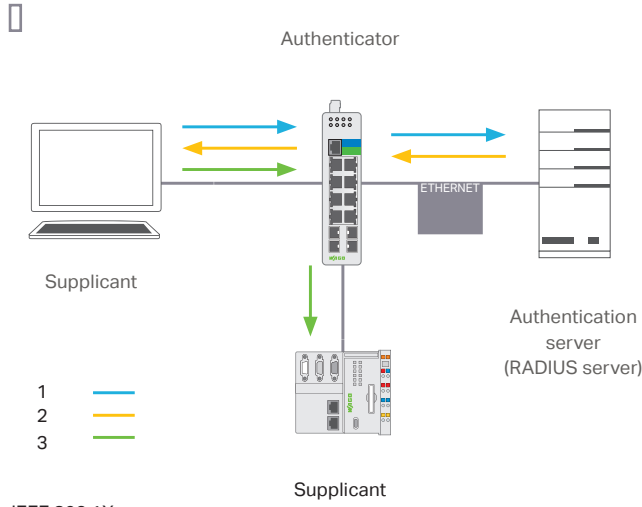

IEEE 802.1X

IEEE 802.1X Authentication The Security Standard for IT Networks

Secure authentication and authorization in ETHERNET networks (locally on the switch or via RADIUS server)

Process:

- Authentication of a subscriber is performed by the authenticator.
- The authenticator checks the authentication information of the subscriber (supplicant) with an authentication server.

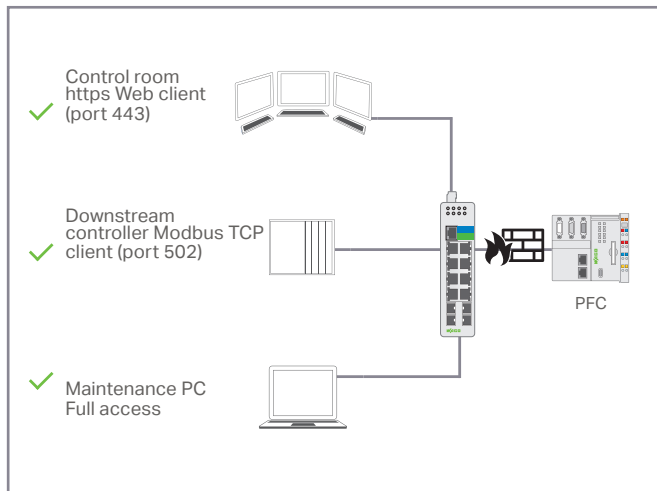

Firewall

Firewall – Access Control List Authorization Only for the Required Services

Filtering data packets via:

- Source MAC or source IP address
- Destination MAC or destination IP address
- Range of MAC or IP addresses
- UDP/TCP source or destination ports

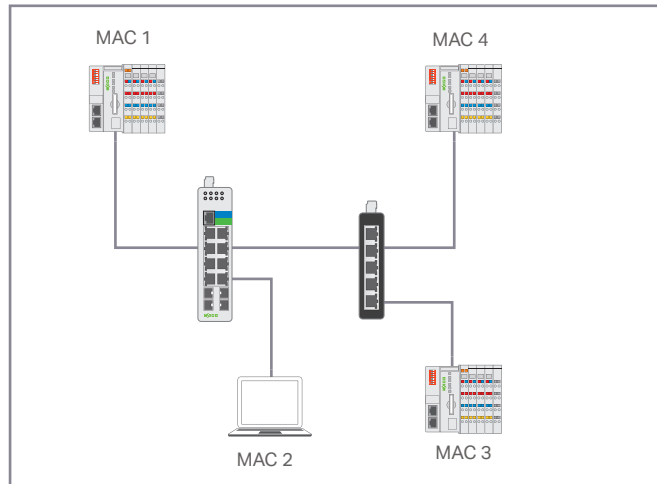

Ports

Port Security MAC Based Firewall

- Dynamically learns MAC addresses for each port
- Limitation of MAC addresses for each port
- MAC-based white/blacklist for each port

Data Transmission

Optimized ETHERNET Networks

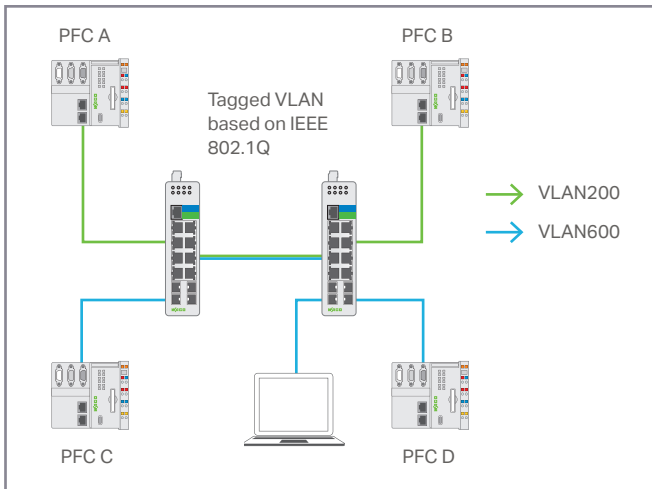

Logical Network Isolation Enhance Network Security

- VLAN (e.g., per IEEE 802.1Q)
Segmentation into logical, virtual networks:
 - Broadcast limitation
 - Security improvement
 - Data flow prioritization
 - Subdivision of machines and office networks

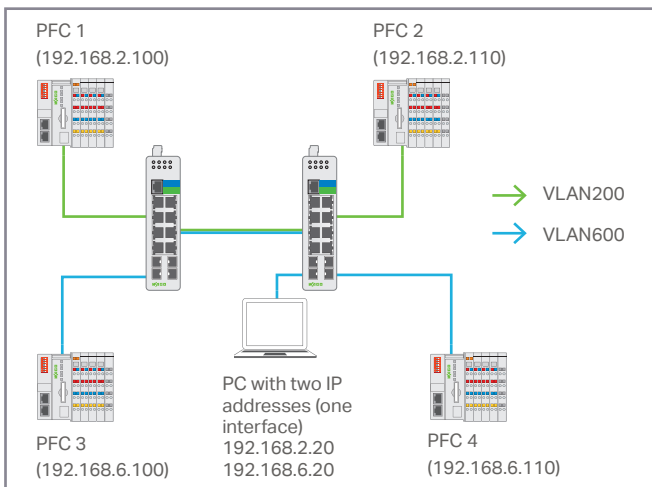

IP-Based VLAN¹ Secure by Known IP

- Routing of data packets between VLANs based on the IP address
- Communication from one participant in two or more VLANs
- Economical connection of networks to higher-level routers
- Prioritization of data packets based on the IP address

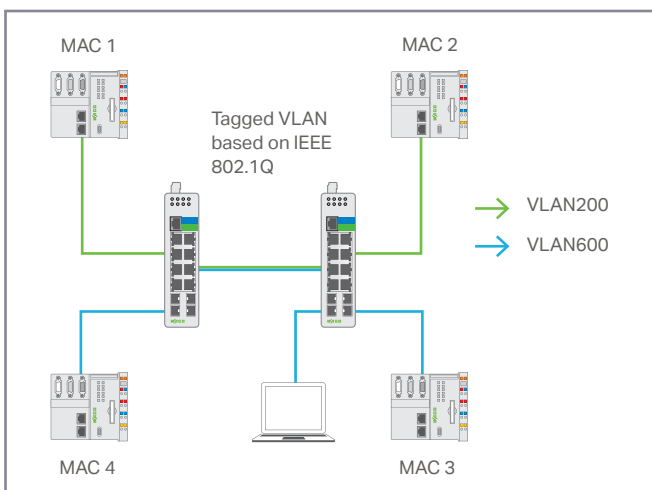

MAC-Based VLAN¹ Secure by Known Device

- Assignment of data packets to a VLAN based on the MAC address
- Prioritization of data packets based on the MAC address

¹ Not available in lean managed switches.

Performance

Optimized ETHERNET Networks

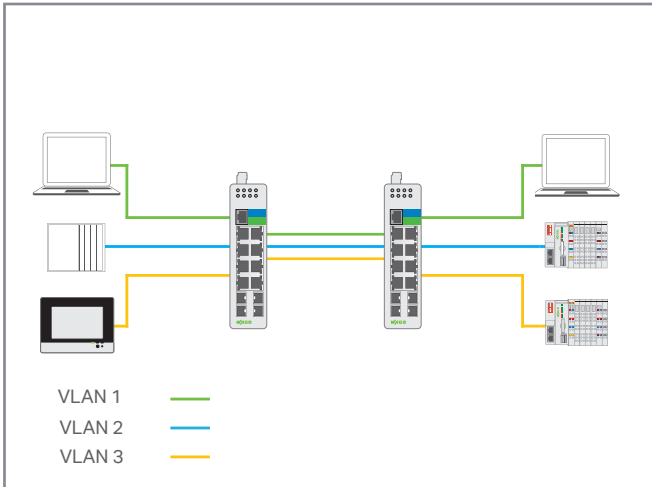

Link Aggregation

Network Optimization

Logical Segmentation

- LACP link aggregation
Merge multiple data connections into a single logical link:
 - Increased transmission rate
 - Link redundancy

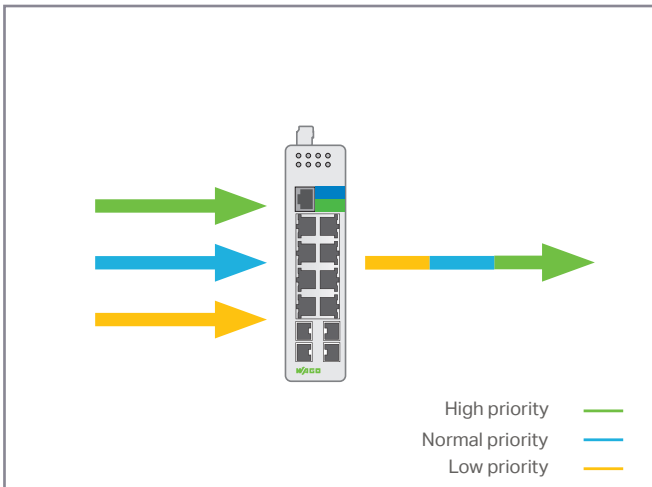

QoS

Traffic Prioritization and Limitation

Controlled Bandwidth

- Faster transfer of important data packets through the switch
- Prioritization of data packets per IEEE 802.1 Q
- Limitation of the bandwidth or number of packets per unit of time per port
- Increase in data transmission quality

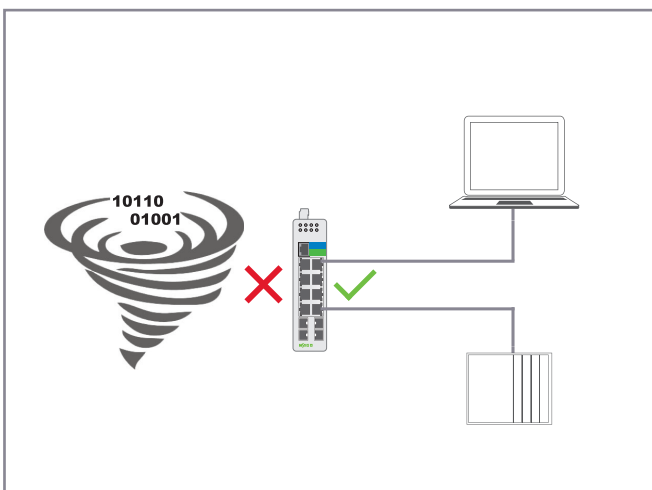

Storm Control

Mastering Data Traffic

High Availability

- Stopping broadcast storms
- Ensuring network availability
- Limiting broadcast and multicast data flows (packets/time)

Administration and Diagnostics

Simplified Commissioning and Maintenance

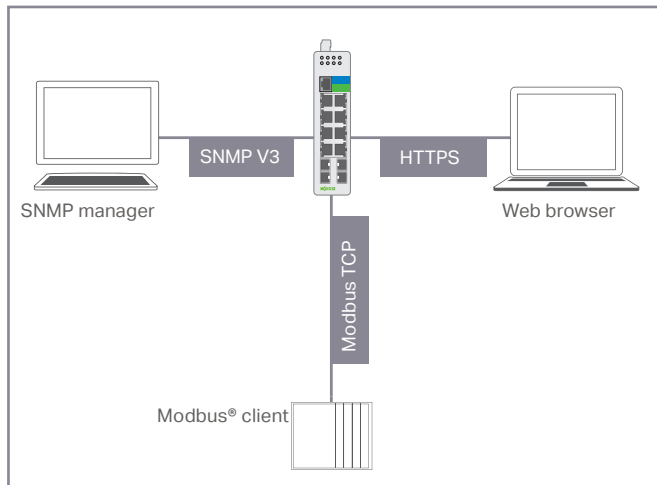

Configuration Interfaces

Configuration and Diagnostics

Several Options

- Configuration via Web-Based Management
- Configuration via command line
- Network management via SNMP v1, v2c, v3
- Support for MIB standards (*Management Information Base*)
- Diagnostics via Modbus TCP
Comprehensive data available for easy diagnostics via Modbus®

SFP Information	
Fiber Cable	Link Up
Connector	LC
Wavelength(nm)	1310
Transfer Distance(nm)	10km, Single mode
DDM Supported(nm)	YES (Internally Calibrated)
Vendor Name(nm)	WAGO
Vendor PN(nm)	852-1210
Vendor rev(nm)	V2.0
Vendor SN(nm)	AX16500009214
Date code(nm)	161209

DDMI Information(nm)					
	Current(nm)	High-Alarm(nm)	Low-Alarm(nm)	High-Warn(nm)	Low-Warn(nm)
Temperature(C)	42.980	90.000	-45.000	85.000	-40.000
Voltage(V)	3.238	3.600	3.000	3.500	3.100
Tx Bias(mA)	21.022	60.000	3.000	50.000	5.000
Tx Power(mW)	0.263	0.631	0.089	0.501	0.112
Tx Power(dBm)	-5.807	-2.004	-10.505	-3.000	-9.506
Rx Power(mW)	0.000	0.631	0.008	0.501	0.010
Rx Power(dBm)	-39.000	-2.004	-21.028	-3.000	-20.000

DDM

DDM: Digital Diagnostic Monitoring¹

Simplify Maintenance and Troubleshooting

- Automatic detection of a connected SFP module
- Detailed module information
- Monitoring in real time
 - Temperature
 - Supply voltage
 - Transmission power
 - Reception power

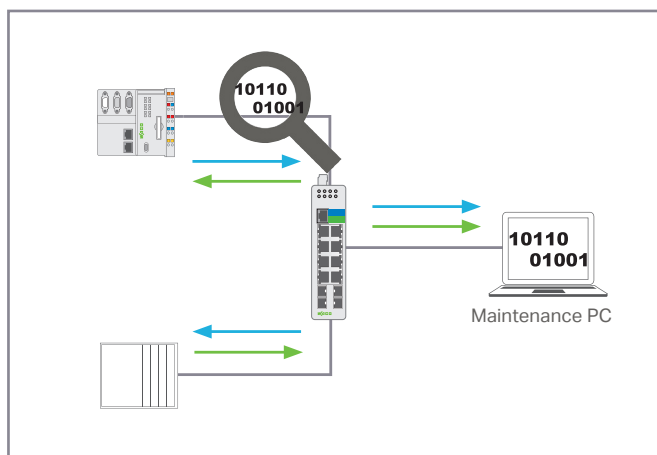

Port Mirroring

Monitoring and Diagnostics

Simplified Maintenance

- Port mirroring:
Mirrors the network traffic
- LLDP:
Automatically detects adjacent devices
- Email notifications

¹ Not available in lean managed switches.

Quick Reference Guide

Unmanaged

ECO

	Fast ETHERNET			GIGABIT		GIGABIT PoE+	
Ports	5 x 10/100	8 x 10/100	8 x 10/100	5 x 10/100/1000	8 x 10/100/1000	5 x 10/100/1000	5 x 10/100/1000
with PoE	-	-	-	-	-	4 x PoE+	4 x PoE+
Fiber-Optic Ports	-	-	-	-	-	-	2 x SFP 1000
Part Number	852-111 /000-001	852-112	852-112 /000-001	852-1111 /000-001	852-1112 /000-001	852-1411 /000-001	852-1417

Standard

	Fast ETHERNET			GIGABIT	
Ports	5 x 10/100	8 x 10/100	8 x 10/100	8 x 10/100/1000	16 x 10/100/1000
Fiber-Optic Ports	-	-	2 x SFP 100	-	-
Part Number	852-101	852-102	852-103	852-1102	852-1106

Managed

Lean

	GIGABIT		GIGABIT PoE+	
Ports	8 x 10/100/1000	8 x 10/100/1000	16 x 10/100/1000	8 x 10/100/1000
with PoE+	-	-	-	8 x PoE+
Fiber-Optic Ports	-	2 x SFP 1000	-	2 x SFP 100/1000
Part Number	852-1812/010-111	852-1813/010-000	852-1816	852-1813/000-001

Standard

	Fast ETHERNET	GIGABIT	GIGABIT PoE+
Ports	8 x 10/100	8 x 10/100/1000	8 x 10/100/1000
with PoE+	-	-	8 x PoE+
Fiber-Optic Ports	2 x SFP 100/1000	4 x SFP 1000	4 x SFP 1000
Part Number	852-303	852-1305/000-001	852-1505/000-001

PROFINET

	PROFINET		
Ports	8 x 10/100	8 x 10/100	8 x 10/100/1000
Fiber-Optic Ports	-	2 x SFP 100/1000	4 x SFP 1000
Part Number	852-602	852-603	852-1605

MACsec

	GIGABIT	
Ports	8 x 10/100/1000	6 x 10/100/1000
with MACsec	2 x RJ45	2 x SFP
Part Number	852-1322	852-1328

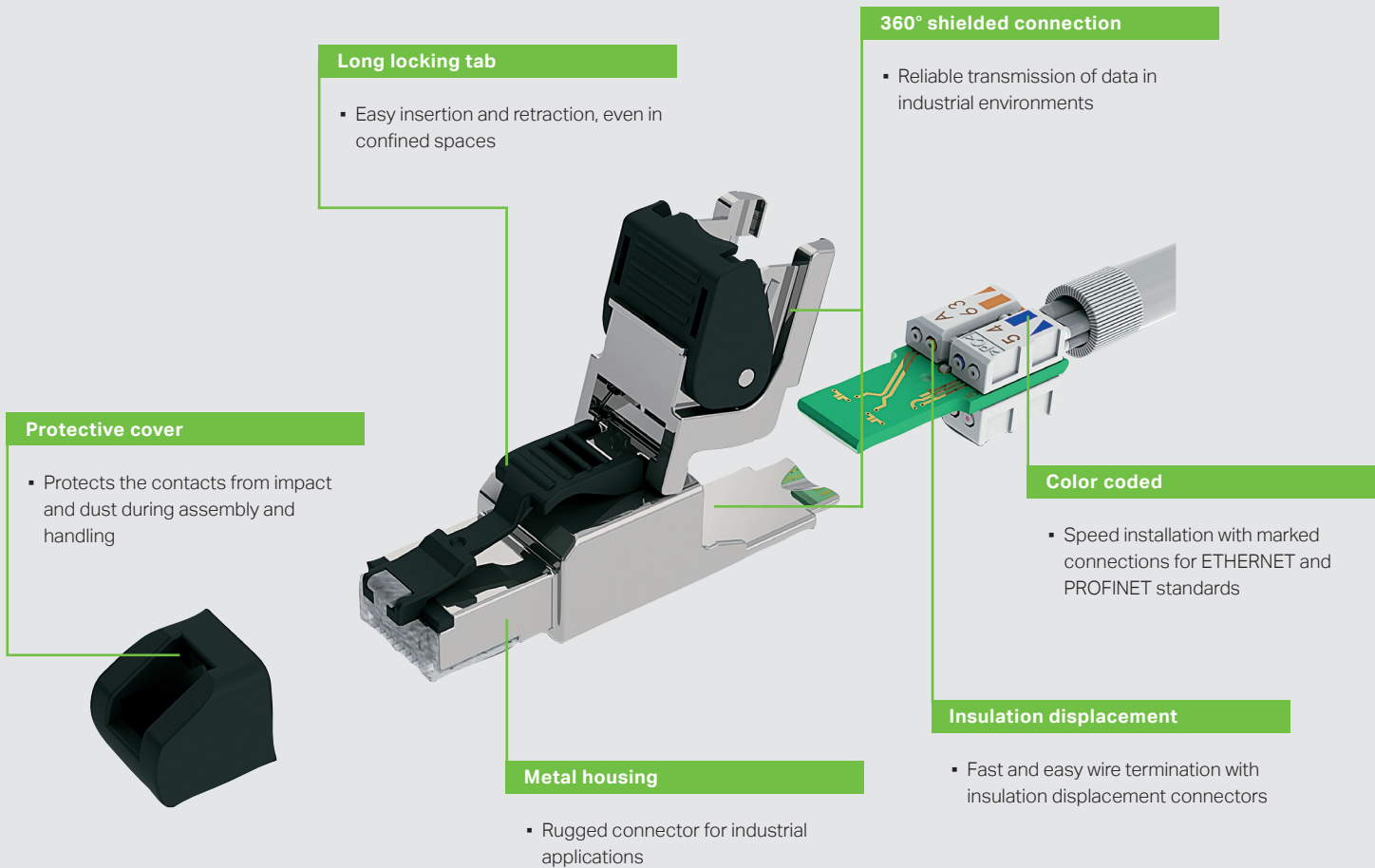

Cat 6A RJ45 Connectors

Fast and Tool-Free Installation

RJ45 Connectors			
Category	Cat 6A	Cat 6A	Cat 6A
Max. rate	10 Gbit/s	10 Gbit/s	10 Gbit/s
Housing material	Metal	Metal	Metal
Surrounding air temperature (operation)	-40 ... +85 °C -40 ... +185 °F	-40 ... +85 °C -40 ... +185 °F	-40 ... +85 °C -40 ... +185 °F
Cable clamp	-	Straight output	Angled output
Conductor cross-section¹	22 AWG	22 AWG	22 AWG
ETHERNET T568B²	750-977/000-012	750-978/000-012	750-979/000-012
PROFINET³	750-977/000-013	750-978/000-013	750-979/000-013

¹ Also available for conductors ranging from 24 AWG, Item No. 750-97x/000-02x

² Also available for ETHERNET T568A, Item No. 750-97x/000-011

³ Max. rate for PROFINET: 100 Mbit/s

Features

- Category 6
- PoE and PoE+ compatible



Simple handling without specialty tools

- Insulation displacement connectors
- Dual labeling: T568A and T568B

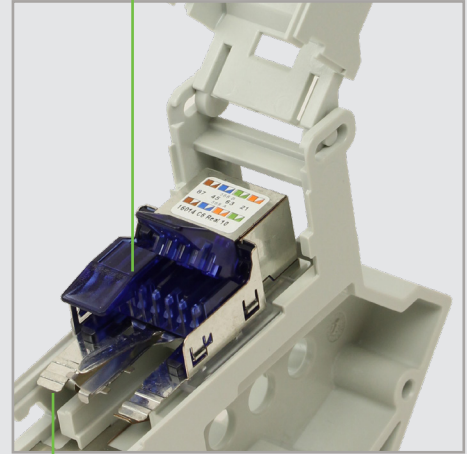

Shielded connection

- Safe transmission of data

DIN Rail Mount RJ45 Interfaces

ETHERNET Cabling on DIN Rail

RJ45 Interfaces

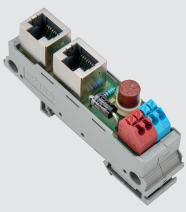
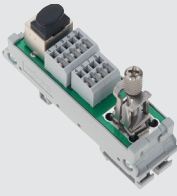
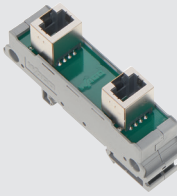
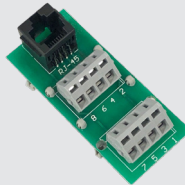
					
Category	Cat 6	Cat 5	Cat 5	Cat 5	-
Description	Cable to RJ45	Passive PoE Injector	Cable to RJ45	RJ45 to RJ45	Cable to RJ45
Max. Output	10 Gbit/s	100 Mbit/s	100 Mbit/s	100 Mbit/s	100 Mbit/s
Dimensions (W x H x D)	26.8 x 64.4 x 81.4 mm 1 x 2.5 x 3.2 in	20.5 x 51 x 85 mm 0.79 x 2 x 3.4 in	24 x 40 x 85 mm 1 x 1.6 x 3.4 in	20.5 x 51 x 85 mm 0.79 x 2 x 3.4 in	31 x 33 x 71 mm 1.22 x 1.3 x 2.8 in
Connection	IDC	CAGE CLAMP®	CAGE CLAMP®	-	CAGE CLAMP®
Temperature	-10 ... +60 °C +14 ... +140 °F	-40 ... +85 °C -40 ... +185 °F	-40 ... +85 °C -40 ... +185 °F	-40 ... +85 °C -40 ... +185 °F	-40 ... +40 °C -40 ... +104 °F
Shield Clamp	No	No	Yes	No	No
Conductors Section	24 ... 22 AWG	24 ... 16 AWG	28 ... 14 AWG	-	28 ... 12 AWG
Part Number	289-195	289-196	289-175/790-108	289-172	289-171/000-236

Large choice of SFPs



Mechanical lock

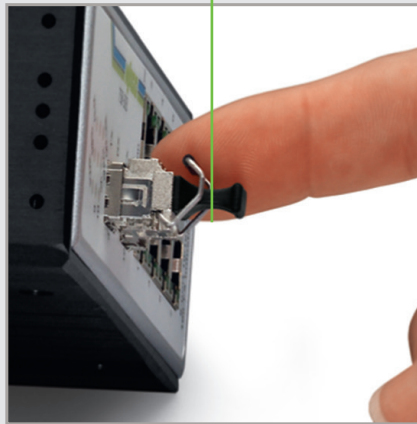

Single and multimode types

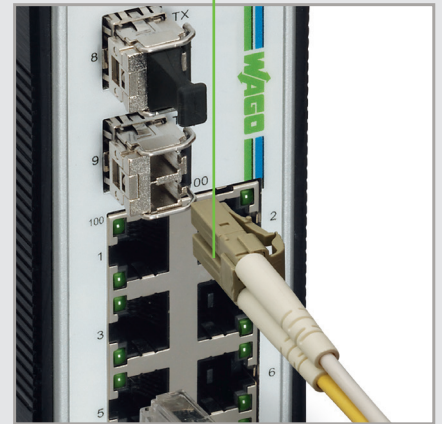

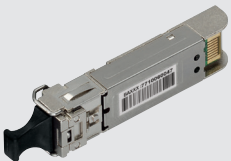
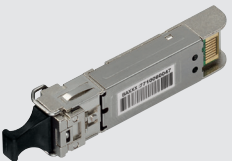

SFP Modules

Interfaces for Fiber-Optic

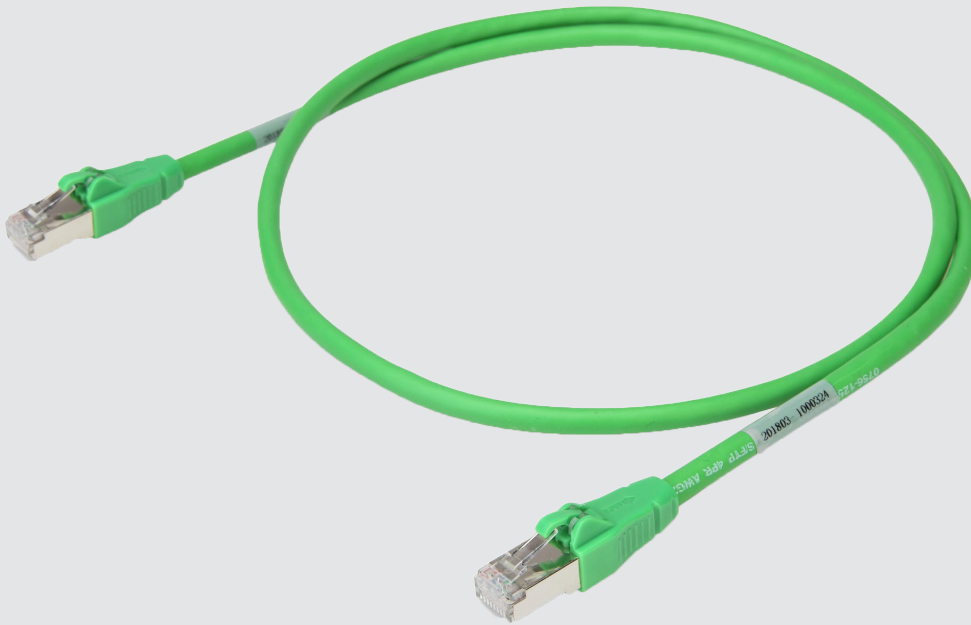
Category	Fast ETHERNET		Gigabit		
					
	100BASE-FX	100BASE-FX	1000BASE-SX	1000BASE-LX	1000BASE-ZX
Laser Type	Multimode	Single-mode	Multimode	Single-mode	Single-mode
Wavelength	1310 nm	1310 nm	850 nm	1310 nm	1550 nm
Max. Distance	2 km / 1.2 mi	30 km / 18.5 mi	0.55 km / 0.4 mi	10 km / 6.2 mi	80 km / 49.7 mi
DDM*	No	No	Yes	Yes	Yes
Connector	LC duplex	LC duplex	LC duplex	LC duplex	LC duplex
Operating Temp.	-40 ... +70 °C -40 ... +158 °F	-40 ... +70 °C -40 ... +158 °F	-40 ... +85 °C -40 ... +185 °F	-40 ... +85 °C -40 ... +185 °F	-40 ... +85 °C -40 ... +185 °F
Part Number	852-202	852-201/107-030	852-1200	852-1210	852-1280
Compatible with	852-103, 852-303 852-603, 852-1328, 852-1813/000-001, 852-1813/010-000, 852-1701, 852-1702, 852-1731, 852-1732	852-103, 852-303 852-603, 852-1328, 852-1813/000-001, 852-1813/010-000, 852-1701, 852-1702, 852-1731, 852-1732	852-303, 852-603, 852-1505/000-001, 852-1328, 852-1417, 852-1505/000-001, 852-1605, 852-1813/000-001, 852-1813/010-000, 852-1701, 852-1702, 852-1731, 852-1732	852-303, 852-603, 852-1505/000-001, 852-1328, 852-1417, 852-1505/000-001, 852-1605, 852-1813/000-001, 852-1813/010-000, 852-1701, 852-1702, 852-1731, 852-1732	852-303, 852-603, 852-1505/000-001, 852-1328, 852-1417, 852-1505/000-001, 852-1605, 852-1813/000-001, 852-1813/010-000, 852-1701, 852-1702, 852-1731, 852-1732



Patch Cables

Patch Cables	Standard	Axial Release
		
0.5 m / 1.6 ft	756-1250/1013-005	756-1250/1023-005
1 m / 3.3 ft	756-1250/1013-010	756-1250/1023-010
2 m / 6.6 ft	756-1250/1013-020	756-1250/1023-020
3 m / 9.8 ft	756-1250/1013-030	756-1250/1023-030
5 m / 16.4 ft	756-1250/1013-050	756-1250/1023-050
7.5 m / 24.6 ft	756-1250/1013-075	756-1250/1023-075
10 m / 32.8 ft	756-1250/1013-100	756-1250/1023-100

Features

- Cat 6A S/FTP
- Up to 10 Gb/s
- Gold contacts
- Mechanically and electrically tested
- Halogen free
- Flame retardant and low smoke emission
- > 1200 connections/deconnections



Mounting

- Easy installation onto DIN rail

Connection

- RJ45 connection
- 1 Gb ETHERNET transmission speeds
- 48 VDC PoE data line protection

WAGO Protect

1 Gb/s PoE ETHERNET Surge Protection

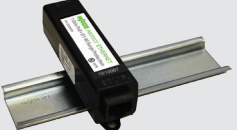
ETHERNET Surge Devices	1 Gb/s PoE+	1 Gb/s PoE++
		
Max. PoE Power	51 Watts	100 Watts
Nominal Voltage	48 VDC	48 VDC
Max. PoE Current Per Pin	600 mA	1.5 A
Suitable for Non-PoE	Yes	Yes
Technology	Gas discharge tube	Hybrid gas discharge tube and silicon avalanche diode
Protection Modes	Line-to-ground, shield-to-ground	Line-to-line, line-to-ground, shield-to-ground
Pins Protected	[1, 2] [3, 6] [4, 5] [7, 8] {Shield}	[1, 2] [3, 6] [4, 5] [7, 8] {Shield}
Surge Suppression Line to Line	N/A	< 75 Vpk @ 100 A 8/20 μs
Max. Surge Current Line to Ground	1 kA (8/20 μs)	2 kA (8/20 μs)
Max. Surge Current Shield to Ground	20 kA (8/20 μs)	20 kA (8/20 μs)
Response Time	< 75 ns	< 5 ns
Connections	Inline RJ45 Cat 5 e shielded	Inline RJ45 Cat 5 e shielded
Operating and Storage Temp.	-40 ... +75 °C; -40 ... +167 °F	-40 ... +75 °C; -40 ... +167 °F
Relative Humidity	99% (non-condensing)	99% (non-condensing)
UL Certification	497B	497B
ETHERNET Protocol	IEEE 802.3	IEEE 802.3
Part Number	60366569	60366571

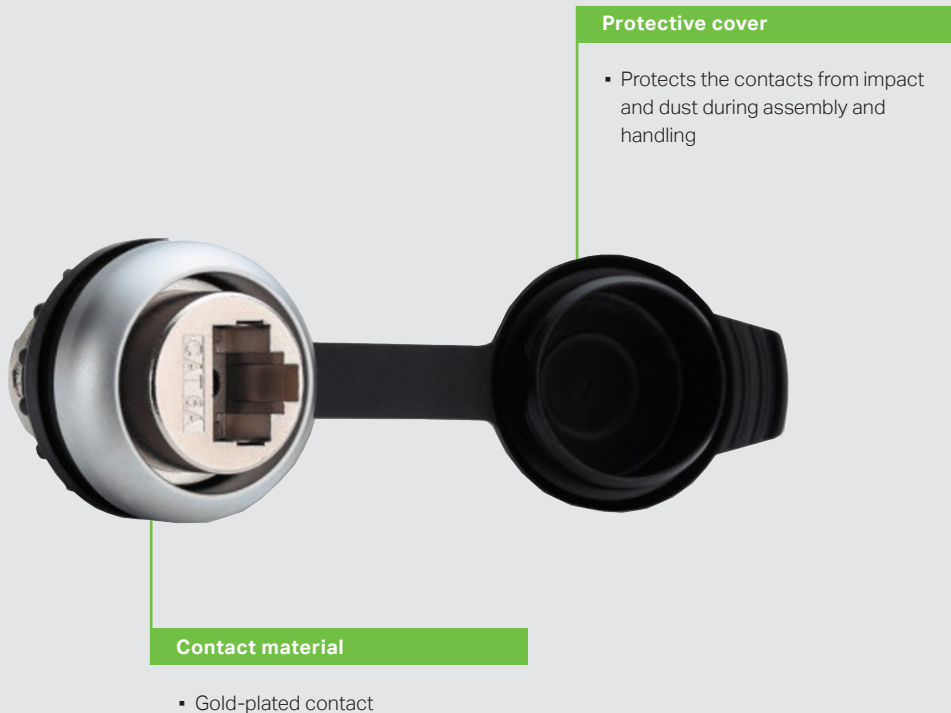

Bulkhead Sockets

Convenient Way to Pass RJ45 or USB Networks Through a Control Enclosure

Bulkhead Sockets		
		
Description	Cat 6A panel connector	USB 3.0 panel connector
Contact Material	CuSn, gold-plated	CuSn, gold-plated
Protection Class	IP65 and NEMA UL Type 2, 3R, 4, 4X, 12, 13 with cap closed	IP65 and NEMA UL Type 2, 3R, 4, 4X, 12, 13 with cap closed
Operating Temperature Range	-20 ... +70 °C -4 ... +158 °F	-20 ... +70 °C -4 ... +158 °F
Storage Temperature Range	-20 ... +80 °C -4 ... +176 °F	-25 ... +80 °C -13 ... +176 °F
Temperature Range Connector	-20 ... +70 °C	-
Transfer Rate	10 Gbit/s	5 Gbit/s
Category	Cat 6A	-
USB Standard	-	3.0
Approvals	cULus	cULus
Part Number	8000-099/0000-1764	8000-099/0000-1765

WLAN 802.11 a/b/g/d/e/i/h and Bluetooth 4.0

- Robust communication with high data throughput

High IP65 protection class

- For direct on-machine use

Access point functionality

- Build a network of up to 7 clients



Version with external antenna

- Omni-directional signal pattern

Button

- Easy configuration
- Advanced configuration via Web server or Telnet

Diagnostic LEDs

- Supply voltage
- Network connections
- Wireless signal quality



Wireless Ethernet Gateway

Copper Cable Replacement

Wireless Ethernet Gateway



Antenna	Internal directional antenna	External antenna ²
Security Encryption	WEP64, WEP128, TKIP, AES/CCMP	
Transmission Range	400 m / 1,300 ft.	
Frequency Band	ISM band, 2.4 GHz (Bluetooth®, WLAN); ISM band, 5 GHz (WLAN)	
Security Authentication	WPA/WPA2 PSK, LEAP, PEAP	
Power Supply	24 VDC (9 ... 30 V)	
Temperature	-30 ... +65 °C -22 ... +149 °F	
Protection Type	IP65	
Approvals	CE, FCC, IC, UL ¹	
Part Number	758-918	758-918/000-0001

¹ Pending ² Antenna included

Application – Wireless ETHERNET Gateway

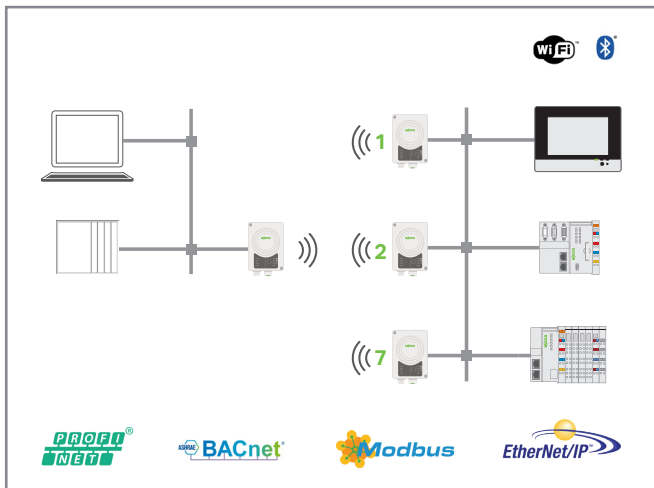

ETHERNET Bridge

Replacement of Network Cables

- Transmission of each TCP/IP also of prioritized PROFINET RT and ETHERNET/IP frames
- Pairing via device's push-button
- Up to seven clients
- Use of Wi-Fi or *Bluetooth*[®]

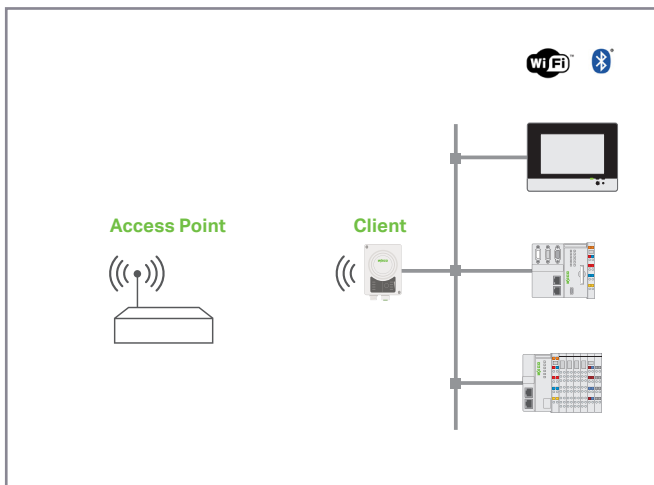

Client for Existing Access Point

Connect to Plant Networks

- Connection to a network of type Wi-Fi 802.11a/b/g/d/e/i/h
- Protocols like Modbus TCP, ETHERNET/IP, BACnet/IP ...
- Possibility of connecting multiple devices after the client

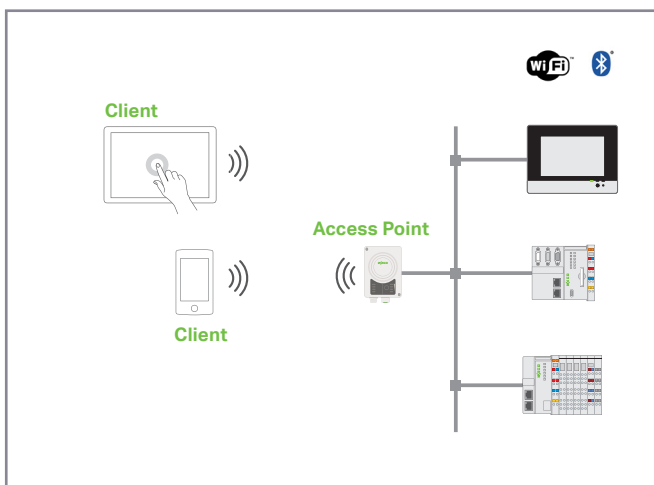

Access Point

Smart Devices for Operator Interface

- Setup of a Wi-Fi 802.11a/b/g/d/e/i/h or *Bluetooth*[®] network
- Connection of tablets, smartphones etc.
- Up to seven clients simultaneously



Industrial Gigabit PoE Injectors

PoE Budget	60 Watts	90 Watts
Port	10/100/1000 Mbps	8 x 10/100/1000 Mbps
Power Supply	24-57 VDC	24-57 VDC
Operating Temperature	40 °C ... +75 °C -40 °F ... 167 °F	40 °C ... +75 °C -40 °F ... 167 °F
Dimensions	cULus	cULus
Part Number	852-1731	852-1732

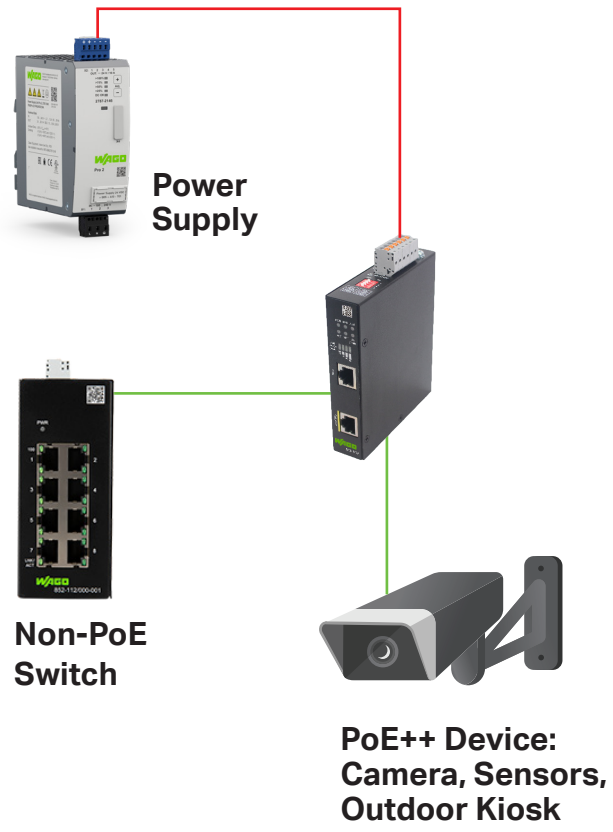

RJ-45 Ethernet Port

- 100/1000 Mbps
- Auto Negotiation
- Non-PoE and PoE+ Versions



Power Connection

- Pluggable Connector

Fiber Optic SFP Port

- 100/1000 Mbps
- Auto Negotiation
- Use with any WAGO SFP Module

Industrial Media Converts

PoE Budget	Not PoE	30 Watts
RJ45 Port	100/1000 Mbps	100/1000 Mbps
SFP Fiber Module	Use WAGO SFPs Pg 22	Use WAGO SFPs Pg 22
Power Supply	12-57 VDC	48-57 VDC
Operating Temperature	40 °C ... +75 °C -40 °F ... 167 °F	40 °C ... +75 °C -40 °F ... 167 °F
Dimensions	60.5 x 42.5 x 50 mm/ 2.38 x 1.67 x 2 inch	60.5 x 42.5 x 50 mm/ 2.38 x 1.67 x 2 inch
Certifications	cULus	cULus
Part Number	852-1701	852-1702

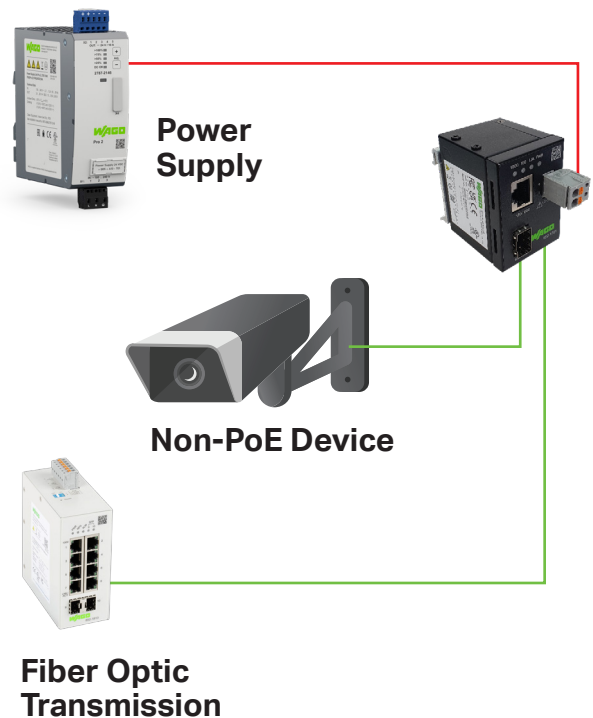

Unmanaged Industrial Switches													
■ = supported		Eco						Standard					
		852-111	852-112	852-112/000-001	852-1111/000-001	852-1112/000-001	852-1411/000-001	852-1417	852-101	852-102	852-103	852-1102	852-1106
Hardware	Number of copper ports	5	8	8	8	5	5	5	5	8	8	8	16
	100 Mbit/s	■	■	■	■	■	■	■	■	■	■	■	■
	1 Gbit/s	-	-	-	■	■	■	■	-	-	-	■	■
	PoE+ ports among these (1 Gbit/s)	0	0	0	0	4	4	4	0	0	0	0	0
	Number of SFP ports	0	0	0	0	0	0	2	0	0	2	0	0
	100 Mbit/s	-	-	-	-	-	-	-	-	-	■	-	-
	1 Gbit/s	-	-	-	-	-	-	■	-	-	-	-	-
	Alarm relays	0	0	0	0	0	0	0	1	1	1	1	1
Approvals, Standards, Certificates	CE	■	■	■	■	■	■	■	■	■	■	■	■
	DNV GL	■	-	-	-	-	-	-	-	-	-	-	-
	UL 61010	■	■	■	■	■	■	■	■	■	■	■	■
	IEC 61850-3	-	-	-	-	-	-	-	-	-	-	-	-
	PROFINET CC-B	-	-	-	-	-	-	-	-	-	-	-	-
Hardware Features	Status LEDs	-	-	-	■	■	■	■	■	■	■	■	■
	Auto-negotiation	■	■	■	■	■	■	■	■	■	■	■	■
	Auto-crossing	■	■	■	■	■	■	■	■	■	■	■	■
	PROFINET CC-A	-	-	-	■	■	■	■	-	-	-	■	■
Configuration	DIP switch (diagnostics)	-	-	-	-	-	-	■	■	■	■	■	■
	Web-Based Management (http, https)	-	-	-	-	-	-	-	-	-	-	-	-
	SNMP (MIB)	-	-	-	-	-	-	-	-	-	-	-	-
	CLI (SSH, Telnet)	-	-	-	-	-	-	-	-	-	-	-	-
	PROFINET Configurator (GSDML file)	-	-	-	-	-	-	-	-	-	-	-	-
USB storage	-	-	-	-	-	-	-	-	-	-	-	-	
Diagnostics	Status LED (LINK active)	■	■	■	■	■	■	■	■	■	■	■	■
	Status LED (LINK down)	-	-	-	-	-	-	■	■	■	■	■	-
	Status LED (alarm)	-	-	-	-	-	-	■	■	■	■	■	■
	SNMP (MIB)	-	-	-	-	-	-	-	-	-	-	-	-
	SNMP traps	-	-	-	-	-	-	-	-	-	-	-	-
	Modbus® register	-	-	-	-	-	-	-	-	-	-	-	-
	Web-Based Management (http, https)	-	-	-	-	-	-	-	-	-	-	-	-
	Dashboard & Topology Map	-	-	-	-	-	-	-	-	-	-	-	-
	PROFINET diagnostics	-	-	-	-	-	-	-	-	-	-	-	-
Neighborhood detection (LLDP)	-	-	-	-	-	-	-	-	-	-	-	-	
Redundancy	Redundant power supply	-	-	-	-	-	-	■	■	■	■	■	■
	Jet Ring	-	-	-	-	-	-	-	-	-	-	-	-
	Xpress Ring	-	-	-	-	-	-	-	-	-	-	-	-
	ETHERNET Ring Protection Switching	-	-	-	-	-	-	-	-	-	-	-	-
	Media Redundancy Protocol (MRP) (client/manager)	-	-	-	-	-	-	-	-	-	-	-	-
	RSTP/STP	-	-	-	-	-	-	-	-	-	-	-	-
Security	Segmentation (VLAN)	-	-	-	-	-	-	-	-	-	-	-	-
	Authentication (IEEE 802.1X)	-	-	-	-	-	-	-	-	-	-	-	-
	Access Control List (MAC, IP, Port)	-	-	-	-	-	-	-	-	-	-	-	-
	Port Security	-	-	-	-	-	-	-	-	-	-	-	-
Data Transmission and Performance	LACP link aggregation	-	-	-	-	-	-	-	-	-	-	-	-
	Prioritization (IEEE 802.1 p)	-	-	-	■	■	■	■	-	-	-	■	■
	Quality of service (IEEE 802.1 Q)	-	-	-	-	-	-	-	-	-	-	-	-
	Bandwidth limitation	-	-	-	-	-	-	-	-	-	-	-	-
	Storm detection	-	-	-	-	-	-	-	-	-	-	-	-
	Routing within VLANs	-	-	-	-	-	-	-	-	-	-	-	-

Managed Industrial Switches															
		Lean				MACsec		Full				PROFINET			
		852-1812/010-000	852-1813/010-000	852-1813/000-001	852-1816	852-1322	852-1382	852-303	852-1305	852-1305/000-001	852-1505/000-001	852-602	852-603	852-1605	
Hardware	Number of copper ports	8	8	8	16	8	6	8	8	8	8	8	8		
	100 Mbit/s	■	■	■	■	■	■	■	■	■	■	■	■		
	1 Gbit/s	■	■	■	■	■	■	-	■	■	■	-	■		
	PoE+ ports among these (1 Gbit/s)	0	0	8	0	0	0	0	0	0	8	0	0		
	Number of SFP ports	0	2	2	0	0	2	2	4	4	4	0	2	4	
	100 Mbit/s	-	■	■	-	-	-	■	-	-	-	-	■	-	
	1 Gbit/s	-	■	■	-	-	■	■	■	■	■	-	■	■	
	Alarm relays	1	1	1	1	-	-	1	1	1	1	1	1	1	
	Approvals, Standards, Certificates	CE	■	■	■	■	■	■	■	■	■	■	■	■	
DNV GL		-	-	-	-	-	-	■	■	-	-	-	-		
UL 61010		■	■	■	■	■	■	■	■	■	■	■	■		
IEC 61850-3		-	-	-	-	-	-	-	-	■	■	-	-		
PROFINET CC-B		-	-	-	-	-	-	-	-	-	-	■	■	■	
Hardware Features	Status LEDs	■	■	■	■	■	■	■	■	■	■	■	■		
	Auto-negotiation	■	■	■	■	■	■	■	■	■	■	■	■		
	Auto-crossing	■	■	■	■	■	■	■	■	■	■	■	■		
	PROFINET CC-A	-	-	-	-	■	■	■	■	■	■	■	■		
Configuration	DIP switch (diagnostics)	■	■	■	■	-	-	■	■	■	■	■	■		
	Web-Based Management (http, https)	■	■	■	■	■	■	■	■	■	■	■	■		
	SNMP (MIB)	■	■	■	■	■	■	■	■	■	■	■	■		
	CLI (SSH, Telnet)	■	■	■	■	-	-	■	■	■	■	■	■		
	PROFINET Configurator (GSDML file)	-	-	-	-	-	-	-	-	-	-	■	■	■	
	USB storage	-	-	-	-	-	-	-	-	■	■	-	-	-	
Diagnostics	Status LED (LINK active)	■	■	■	■	■	■	■	■	■	■	■	■		
	Status LED (LINK down)	■	■	■	■	■	■	■	■	-	-	■	■	■	
	Status LED (alarm)	■	■	■	■	■	■	■	■	■	■	■	■		
	SNMP (MIB)	■	■	■	■	■	■	■	■	■	■	■	■		
	SNMP traps	■	■	■	■	■	■	■	■	■	■	■	■		
	Modbus® register	■	■	■	■	■	■	■	■	■	■	-	-	-	
	Web-Based Management (http, https)	■	■	■	■	■	■	■	■	■	■	■	■		
	Dashboard & Topology Map	■	■	■	■	-	-	-	-	-	-	-	-	-	
	PROFINET diagnostics	-	-	-	-	-	-	-	-	-	-	■	■	■	
Redundancy	Neighborhood detection (LLDP)	■	■	■	■	-	-	■	■	■	■	■	■		
	Redundant power supply	■	■	■	■	■	■	■	■	■	■	■	■		
	Jet Ring	-	-	-	-	-	-	■	■	■	■	-	-	-	
	Xpress Ring	-	-	-	-	-	-	■	■	■	■	-	-	-	
	ETHERNET Ring Protection Switching	■ ^a	■ ^a	■ ^a	■ ^a	-	-	■	■	■	■	-	-	-	
	Media Redundancy Protocol (MRP) (client/manager)	-	-	-	-	-	-	-	-	-	-	■	■	■	
Security	RSTP/STP	■	■	■	■	-	-	■	■	■	■	■	■		
	Segmentation (VLAN)	■ ^b	■ ^b	■ ^b	■ ^b	-	-	■	■	■	■	■	■		
	Authentication (IEEE 802.1X)	■	■	■	■	■	■	■	■	■	■	-	-	-	
	Access Control List (MAC, IP, Port)	■	■	■	■	-	-	■	■	■	■	■	■	■	
Data Transmission and Performance	Port Security	■	■	■	■	-	-	■	■	■	■	-	-	-	
	LACP link aggregation	-	-	-	-	-	-	■	■	■	■	-	-	-	
	Prioritization (IEEE 802.1 p)	■	■	■	■	■	■	■	■	■	■	■	■		
	Quality of service (IEEE 802.1 Q)	■	■	■	■	-	-	■	■	■	■	■	■	■	
	Bandwidth limitation	-	-	-	-	-	-	■	■	■	■	■	■	■	
	Storm detection	■	■	■	■	-	-	■	■	■	■	■	■	■	
Routing within VLANs	-	-	-	-	-	-	■	■	■	■	■	■	■		

^a Supports two ERPS rings with a switching time of less than 800 ms

^b Supports up to 5 VLANs

WAGO Corporation
N120 W19129 Freistadt Road
Germantown, Wisconsin 53022
Telephone: 800 / DIN-Rail (346-7245)
Fax: 262 / 255-3232
info.us@wago.com
www.wago.us

WAGO Canada Inc.
1550 Yorkton Court, Unit 1
Burlington, ON
L7P 5B7
Telephone: 888 / WAGO 221 (924-6221)
info.ca@wago.com
www.wago.ca

WAGO SA DE CV
Carretera estatal 431 Km. 2+200. Lote 99 6
Parque Industrial Tecnológico Innovación Querétaro
El Marques, Qro. 76246
Lada sin Costo: 01 800 288 WAGO (288-9246)
Telefono: 422 / 221-5946
info.mx@wago.com
www.wago.mx

WAGO is a registered trademark of WAGO Verwaltungsgesellschaft mbH.

"Copyright – WAGO Kontakttechnik GmbH & Co. KG – all rights reserved. The content and structure of the WAGO Websites, catalogs, videos, and other WAGO media are subject to copyright. The dissemination or changing of the content of these pages and videos is not permitted. Furthermore, the content may neither be copied nor made available to third parties for commercial purposes. Also subject to copyright are the images and videos that were made available to WAGO Kontakttechnik GmbH & Co. KG by third parties."